

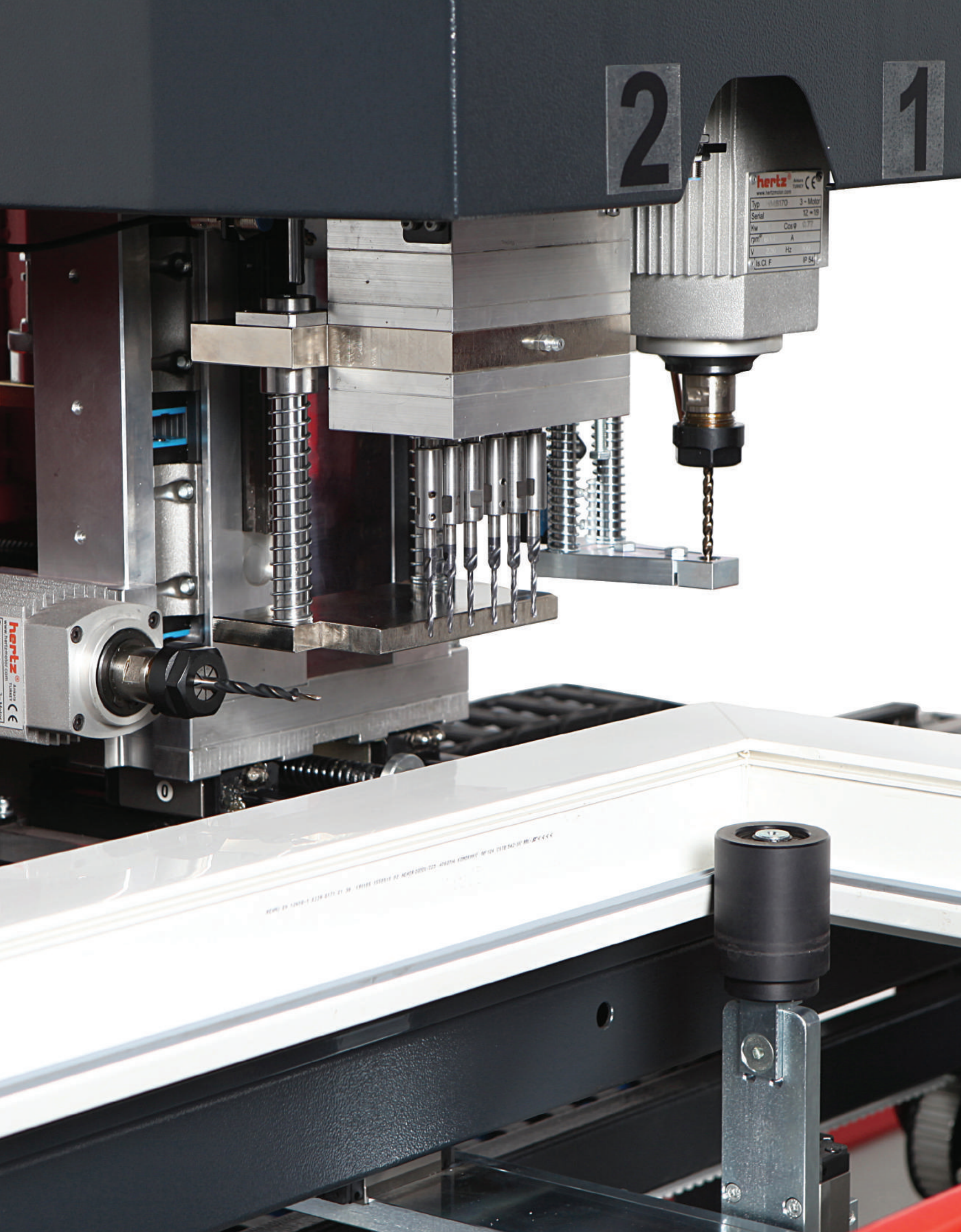

WINDOW AND
DOOR HARDWARE
ASSEMBLY MACHINES

ARTIKON[®]



2

1

hertz
www.hertz.com
Typ 1118170 3-Motor
Serial 12-118
Nw Cosφ 0.77
rpm A
V Hz
In Cl F P-54

hertz
www.hertz.com
CE

RECHENUNG DER WÄRMEDÄMMUNG
RECHENUNG DER WÄRMEDÄMMUNG
RECHENUNG DER WÄRMEDÄMMUNG
RECHENUNG DER WÄRMEDÄMMUNG

BEYOND THE
ORDINARY

ALİŞİLMİŞİN
DİŐİNDÄ

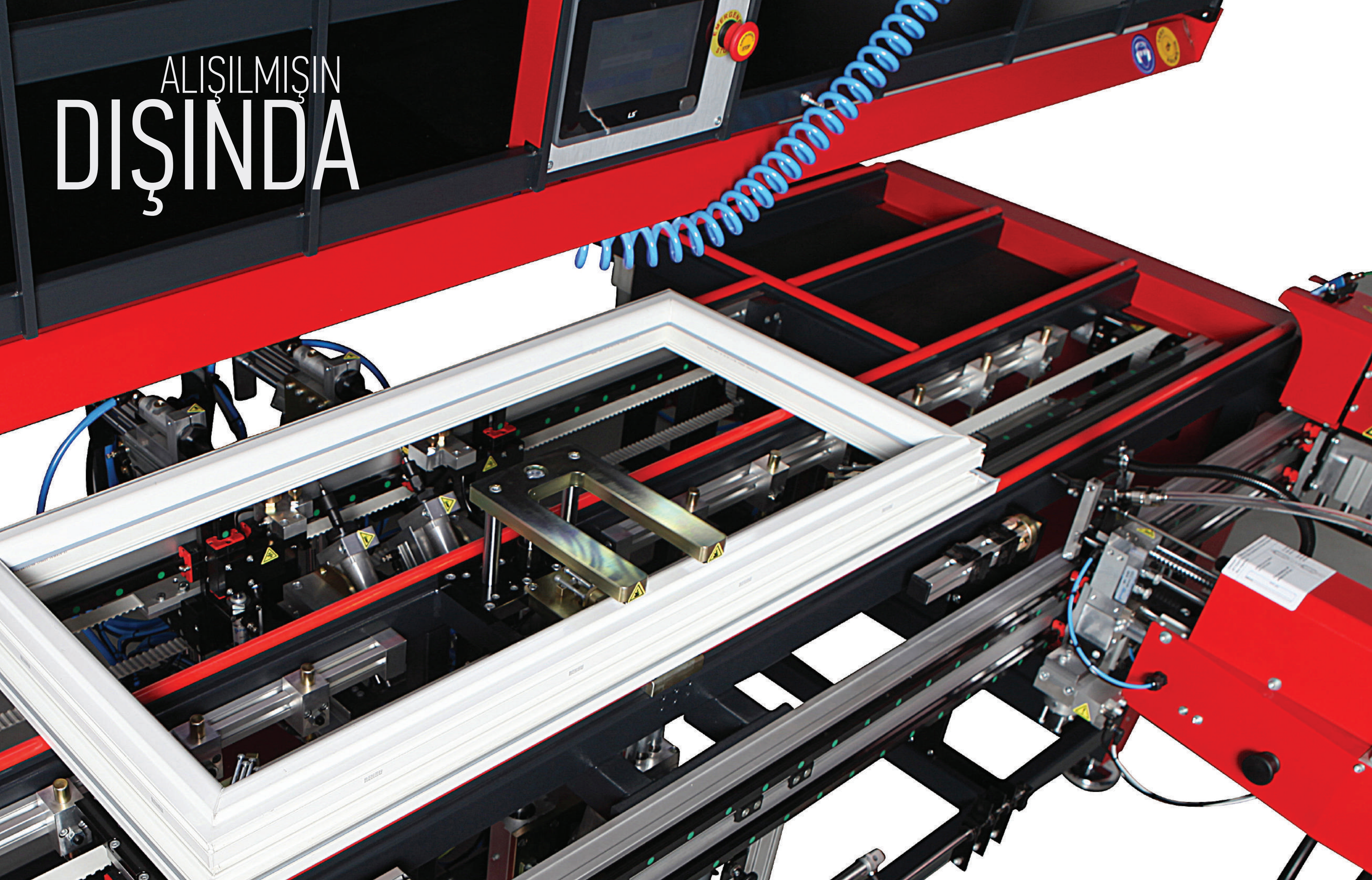

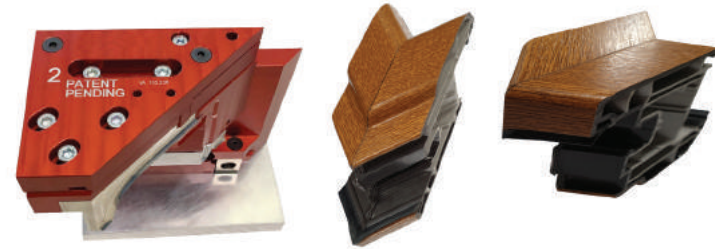
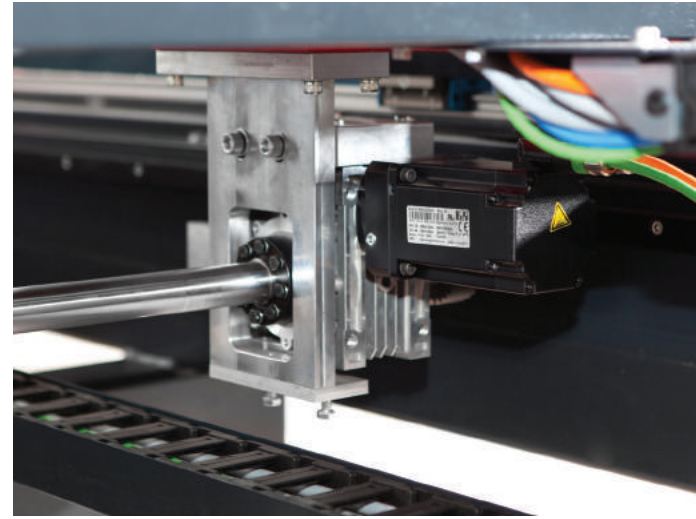
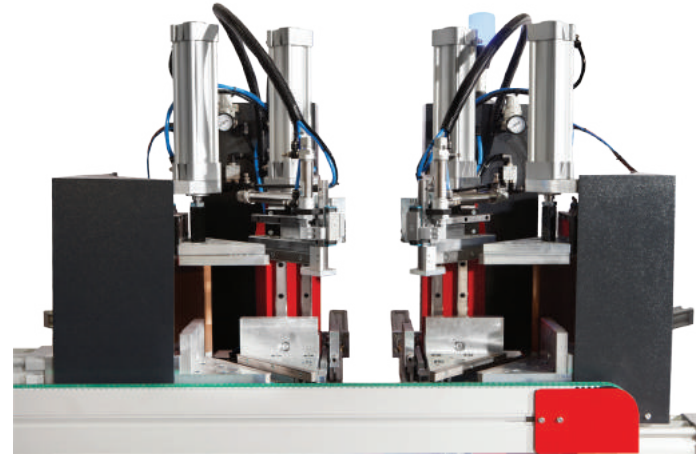

> ÖZELLİKLER

- PVC profillerini 90° açıyla 4 köşesini aynı anda kaynatarak çerçeve haline getirir
- 12" Dokunmatik hareketli sanayi tipi operatör paneli
- CNC kontrol sistemi (3 eksenli)
- Isıtıcı plakalar için teflon sarma sistemi
- Beyaz ve renkli profilleri 0,2 mm kaynak yapabilme olanağı
- Pratik kalıp tasarımı ve kolay değiştirme imkanı
- Resistans ısıtıcıları ekrandan takip edebilme imkanı (farklı profil ısı reçete oluşturma)
- Sertleştirilmiş vidalı mil ve kremayer ekipmanları sayesinde hassas ölçüye gelme imkanı
- 240 - 250 çerçeve / 8 saat

> OPSİYONLAR

- Barkod sistemi
- Conta baskı sistemi
- Kalıp takımları
- Makina çalışma koşullarına göre (ters-düz hat) olabilir
- Kış şartlarında soğuk olan profillerin iyi kaynatılabilmesi için tabla ısıtma sistemi

> FEATURES

- Used to weld four corners of PVC profiles at 90° at the same time
- 12" touch screen panel
- CNC control system (3 axes)
- Resistance teflon wrapping system
- Possibility for 0.2 mm welding for all profile types
- Automatic mould opening system makes the welding seams thinner at separating point. Also easy change mould system.
- Possibility to follow the process of heating the resistance (programming for different profiles)
- Tender measurement system
- 240 - 250 frames / 8 hours

> OPTIONS

- Barcode system
- Gasket clamp system
- Welding moulds
- Can be performed according the working position (reverse or direct line)
- Preheating system for cold profile in winter time.

FW/441

FOUR HEAD WELDING MACHINE

SERVO CONTROL

DÖRT KÖŞE KAYNAK MAKİNASI
SERVO KONTROL

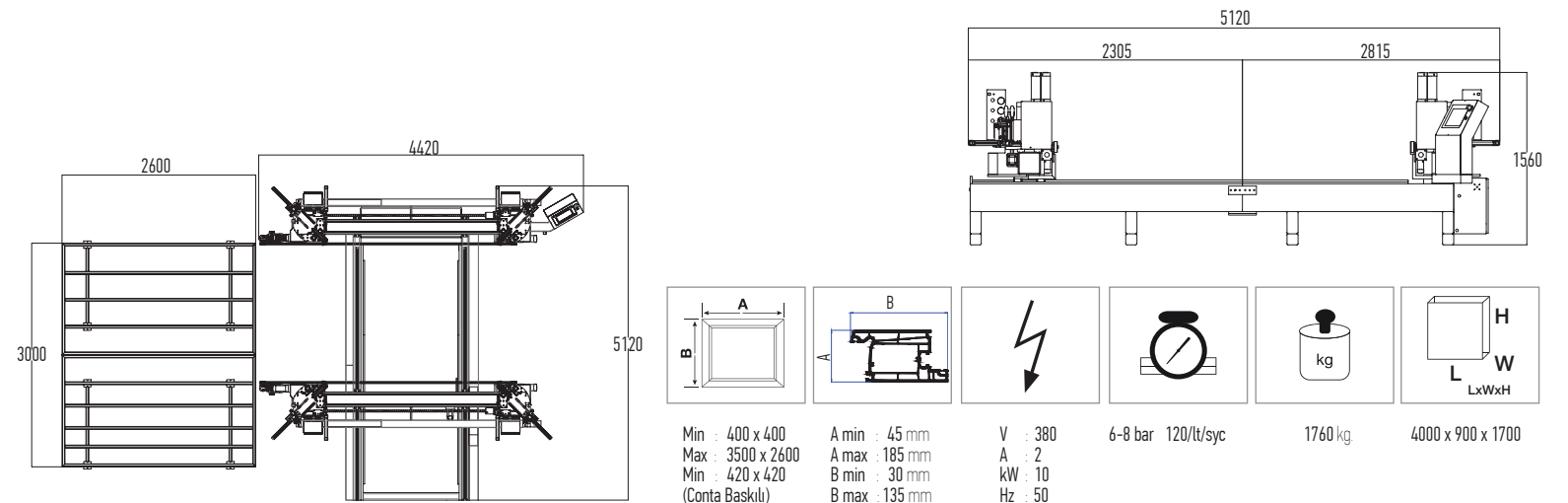
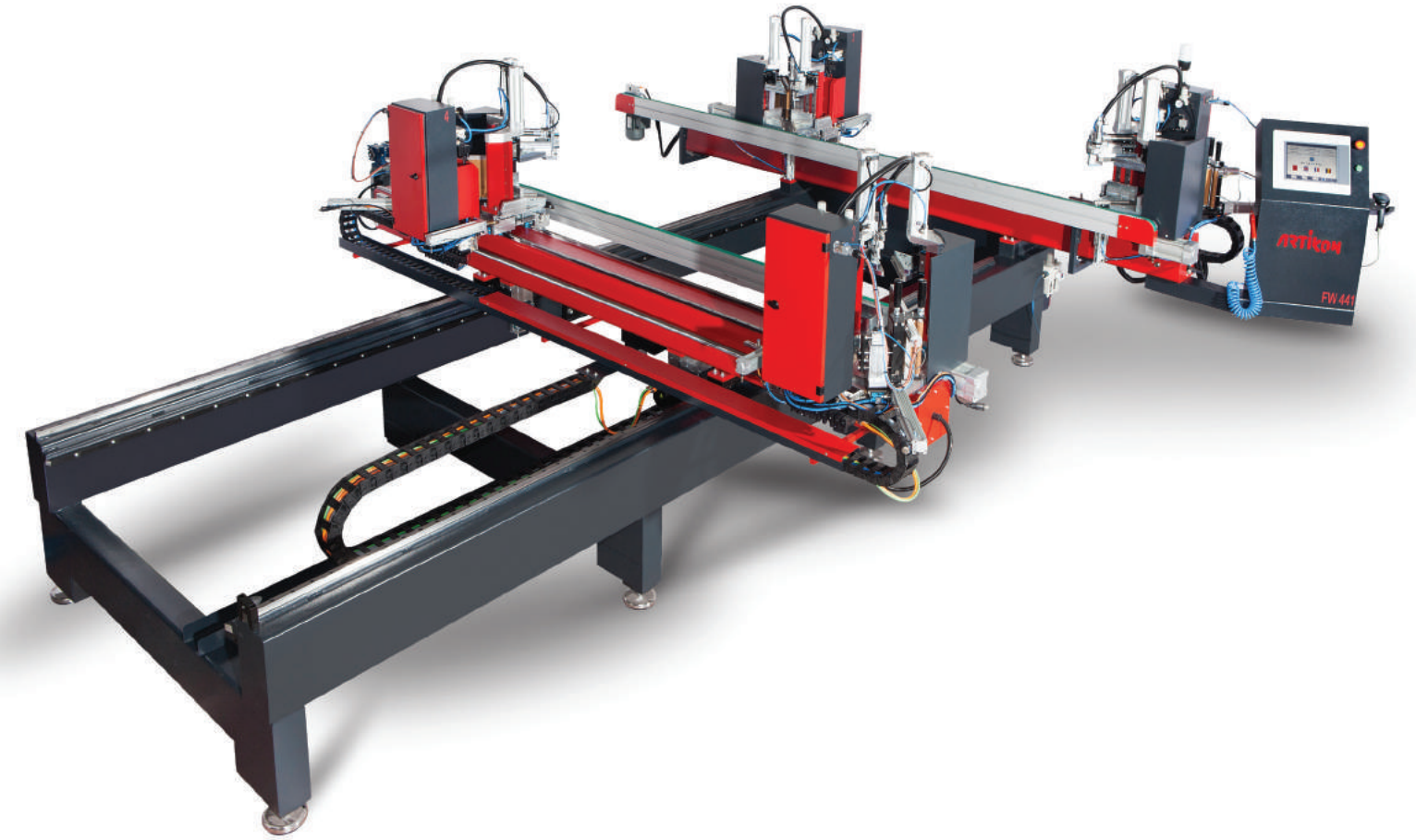

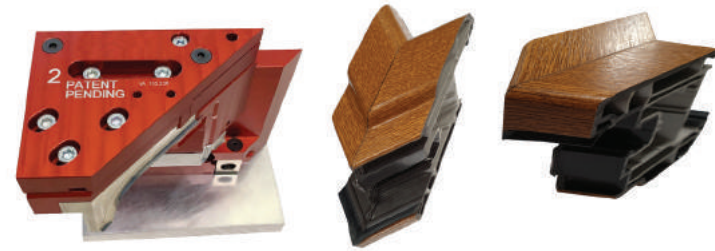
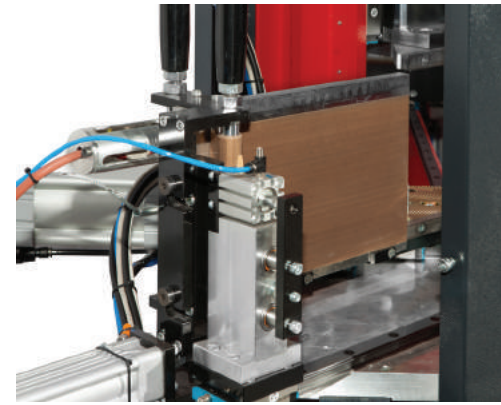
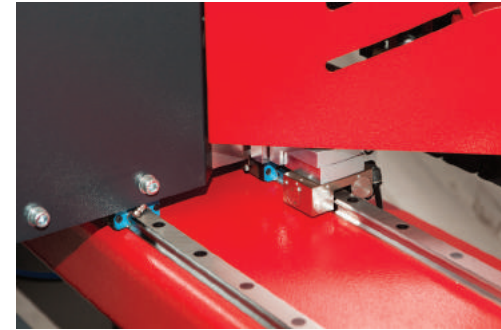
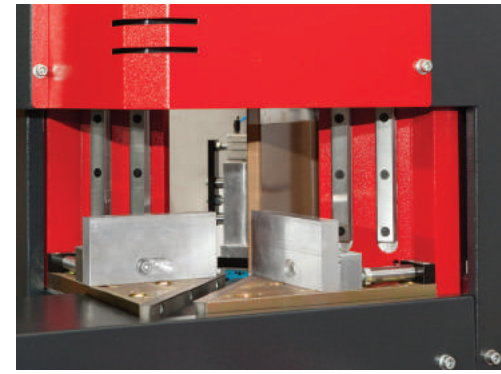
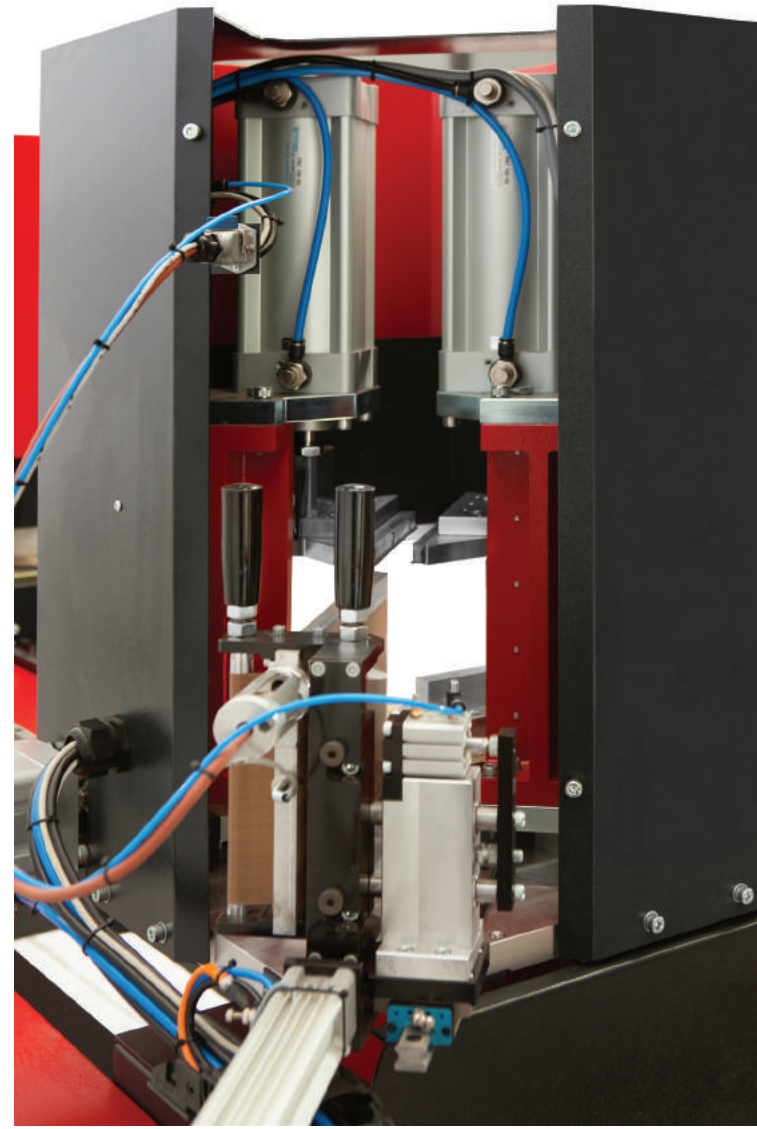

- > PVC profillerin 50° -180° açılarında her iki kafada aynı anda kaynak yapabilme imkanı
- Beyaz ve renkli profilleri 0.2 mm ince kaynak yapar
- Teflon sarma sistemi mevcuttur
- Makinenin tüm hareketli sistemleri lineer ray ve araba üzerinde hareket etmektedir
- Sağlam konstrüksiyonu sayesinde mükemmel kaynak imkanı sağlar
- Kaynak kalplarının stok rafı mevcuttur
- Pratik kaynak kalıbı değiştirmesi imkanı
- Eritme ve yapıştırma süreleri dijital olarak ayarlanır
- Uzun ömürlü ısıtıcı plakalar
- Hareketli kafanın özel hidro-pnömatik ray freni ile sabitlenmesi imkanı
- PLC kontrol sistemi ile farklı profiller için ısı ve zaman reçete programı

> OPSİYONLAR

- Kaynak kalpları
- Tabla ısıtma sistemi
- Conta baskı sistemi

> FEATURES

- Synchronous double corner welding of PVC profiles between 50° -180°
- White and color profiles welding with 0.2 mm seam restriction.
- Special rolled system of teflon
- All movable parts of machine goes on rail system
- At the expense of strong system make a perfect weld
- Stock for welding mould
- Easy mould change system
- Digital control system for weld and press time
- Long lasting heating plates
- The mobile head is stoped by special hidropneumatic system
- PLC control system and programming possibility for different profiles

> OPTIONS

- Welding Mould
- Preheating system for cold profile in winter time.
- Gasket pressing system

DW/241

DOUBLE HEAD WELDING MACHINE

ÇİFT KAFA KAYNAK MAKİNASI

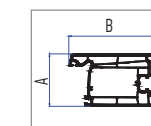
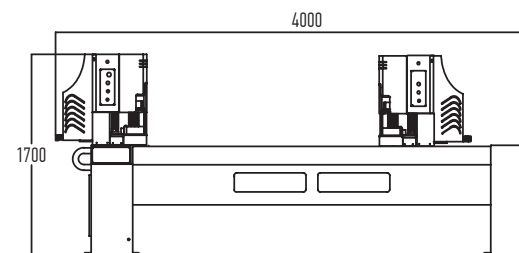

A min : 45 mm
A max : 185 mm
B min : 30 mm
B max : 135 mm

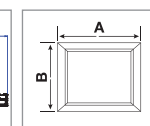

A min : 360 mm
A max : 3000 mm
B min : 300 mm



V : 380
A : 2
KW : 4,5
Hz : 50

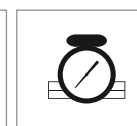

6-8 bar 120/t/syc

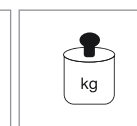

630 kg

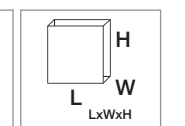

4000 x 900 x 1700

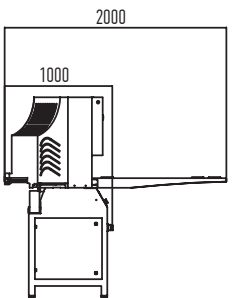

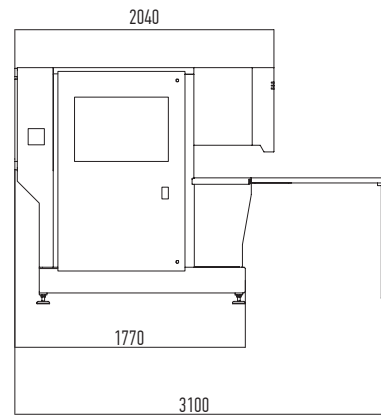
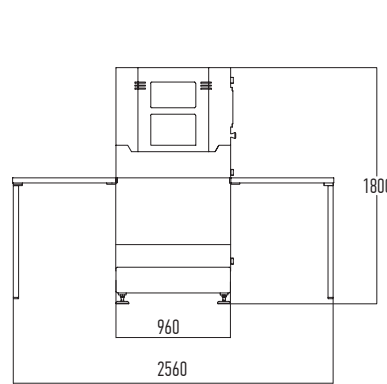
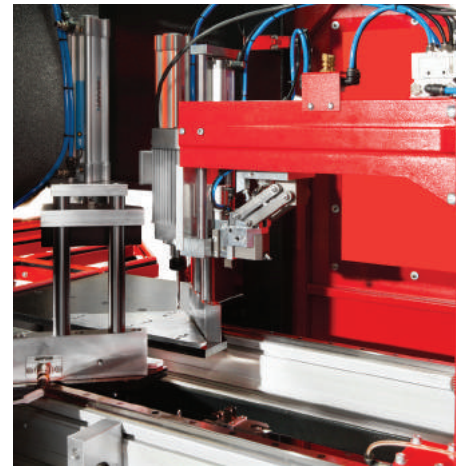

ÖZELLİKLER

- (90° Kaynak edilmiş PVC çerçevelerin kaynak çapaklarını temizleme makinası)
- Hareketli 8,4" dokunmatik Ekran kontrol paneli
- CNC kontrol sistemi (2 eksenli)
- Alt ve üst conta yeri açma frezesi (2 tool)
- Alt ve üst iç köşe temizleme sistemi (patenti) (2 tool)
- Alt ve üst renkli-renksiz yüzey bıçak sistemi (4 tool)
- Dış köşe temizleme testere ø250 (1 tool)
- 9 adet takım (tool) ile köşe temizleme
- Kolay profil programlama ve profil tanımlama sistemi
- Çalışma hızlarının istenilen hızlarda ayarlanabilmesi
- Otomatik yağlama sistemi mevcuttur
- Günlük 190-200 adet / 8 saat çerçeve işleme kapasitesi
- Flash bellek yardımıyla gereken tüm reçeteleri depolama ve başka makineye aktarma imkanı.

FEATURES

- Used to clean the welded corners by 90° of PVC profiles
- Movable 8.4" touch screen panel
- CNC control system (2 axes)
- Up & bottom gasket hole drills (2 tool)
- Up & bottom inner corner cleaning system (special patented design) (2 tool)
- Up & bottom color-colorless surface cleaning blade system (4 tool)
- Frame outside corner cleaning saw ø250 (1 tool)
- Cleaning performance processed by only 9 tool
- Easy system for profile setup and programming
- Adjustment of operating speeds to the desired speed
- Automatic lubrication of oil with over alert system
- Shift processing capacity: 190-200 items / 8 hours
- Unlimited possibility of reserve program files on flash card and send the data to other machine.

CC/222 CNC CORNER CLEANING MACHINE SERVO CONTROL

CNC KÖŞE TEMİZLEME MAKİNASI
SERVO KONTROL

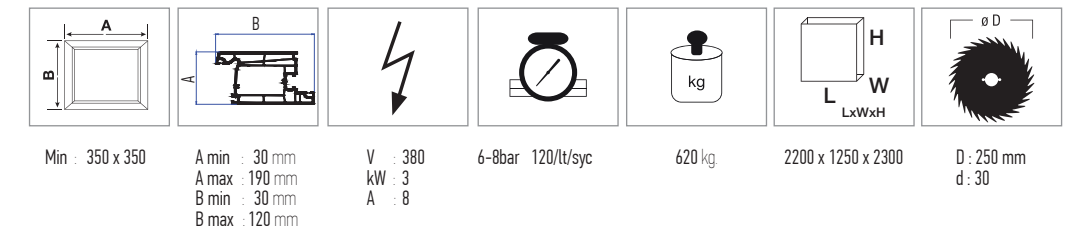

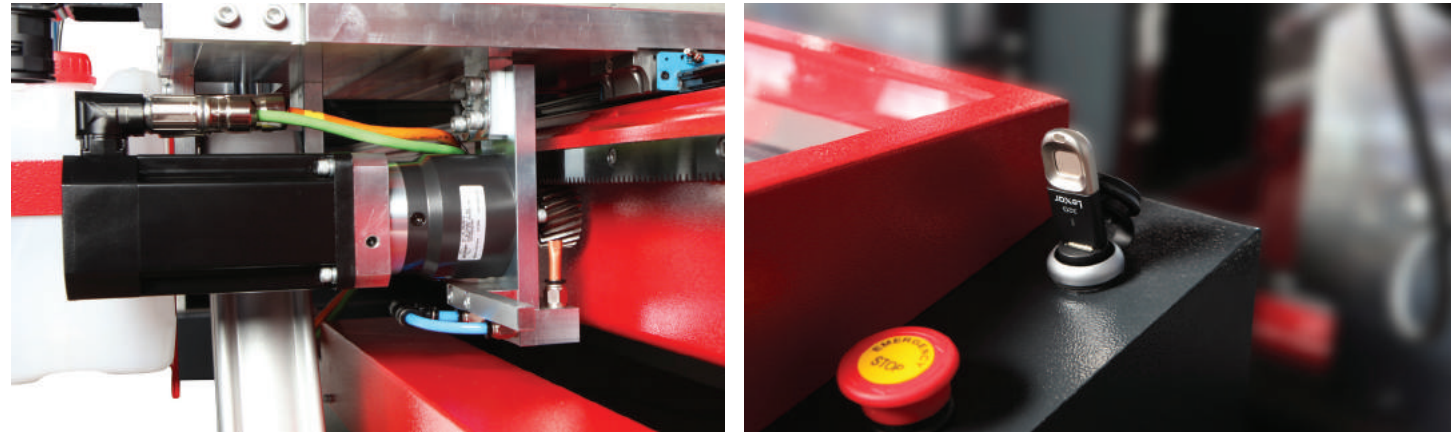
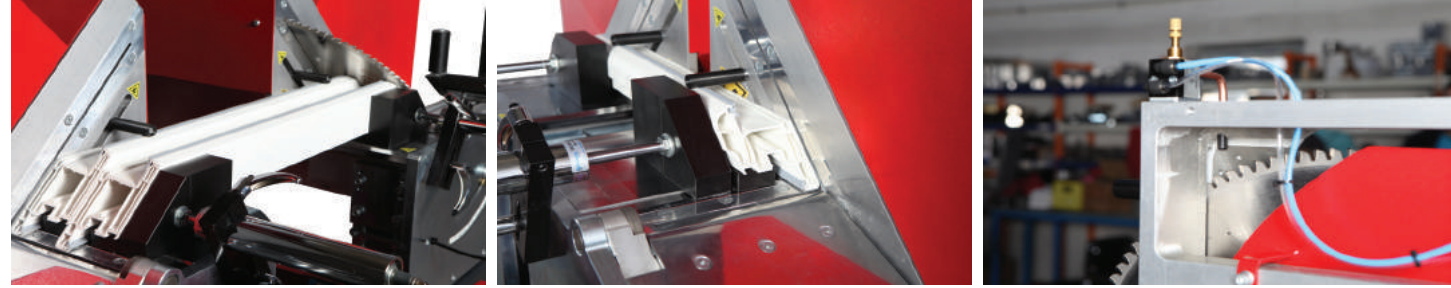

DS/501 AUTOMATIC DOUBLE HEAD MITRE SAW MACHINE SERVO CONTROL

OTOMATİK ÇİFT KAFA KESİM MAKİNASI
SERVO KONTROL

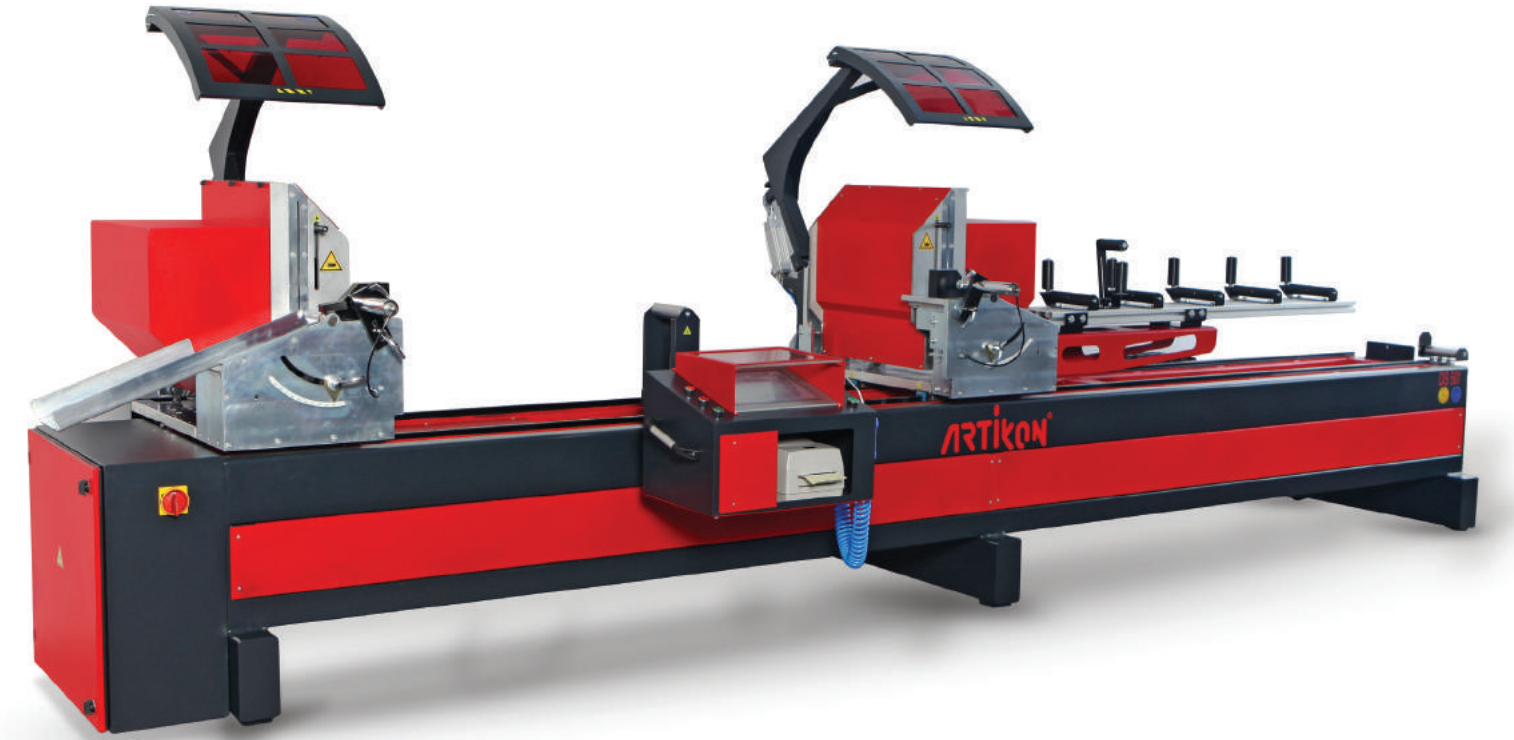

> PVC ve Alüminyum çift köşe kesim testeresi

- Servo motor sayesinde hassas ölçü ve pozisyonlama imkanı
- Testere kafalarının 45° ve 90°'ye otomatik pozisyonlama
- Ara açılar manuel ayarlanmaktadır
- 500 mm çapında testere sayesinde çift profil kesme imkanı
- PVC ve Alüminyum kesim için 2.2 kW güçlü motor kullanılmıştır
- 12,1" Dokunmatik ekran ve PLC kontrol sistemi
- Makinanın tüm hareketli sistemleri lineer ray ve arabalar üzerinde hareket etmektedir
- Otomatik testere muhafazası
- Otomatik dilimleme
- Uzun profil kesme özelliği

> OPSİYONLAR

- Barkod yazıcı
- Alüminyum profil kesimi için soğutma sistemi ve hidro-pnömatik sistem
- Talaş boşaltma manifoldu ile emici ünitesi başlama

> FEATURES

- Double head cutting mitre saw for PVC and Aluminium profiles
- Easy and accurate positioning system by servo motor
- Automatic tilt movement of the saw heads to 45° and 90°
- Angles between 45° and 90° can be adjusted manually.
- The 500 mm saw blade diameter enables to cut 2 profiles at the same time.
- For both PVC and Aluminium cutting is used two 2.2 kW motors.
- 12,1" PLC control system with touchscreen
- All movable parts of machine goes on rail system
- Automatic closing safety system
- Automatic slicing
- Cutting possibility for long profiles

> OPTIONS

- Barcode printer
- Cooling and hydro-pneumatic system to cut aluminum profiles
- Absorbent unit for collecting the sawdust

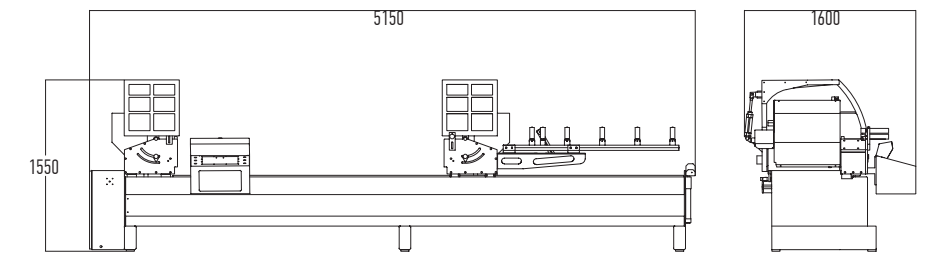
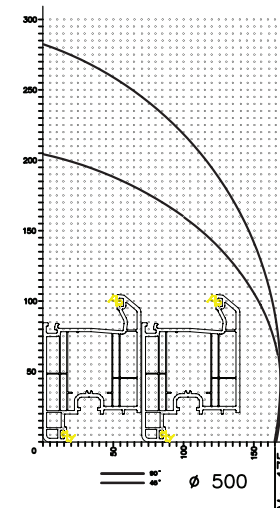

L min : 300mm L max : 4200mm	V : 380 Hz : 50 kW : 5 A : 8	6-8 bar 150/t/syc	1060 kg	5150 x 1250 x 1550 LxWxH	D : 500 mm 2800/min

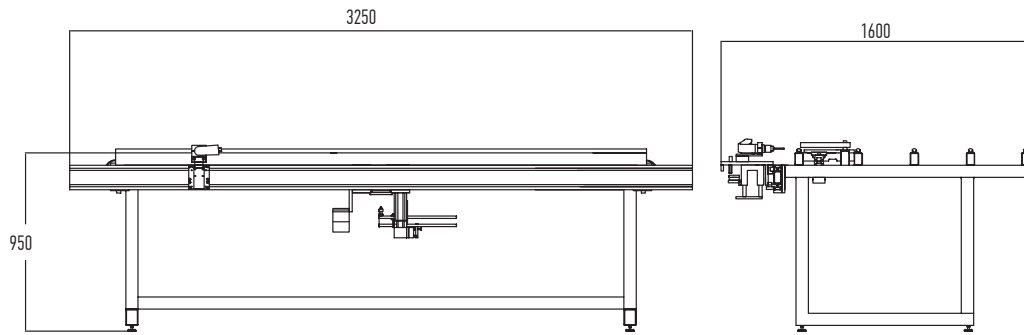
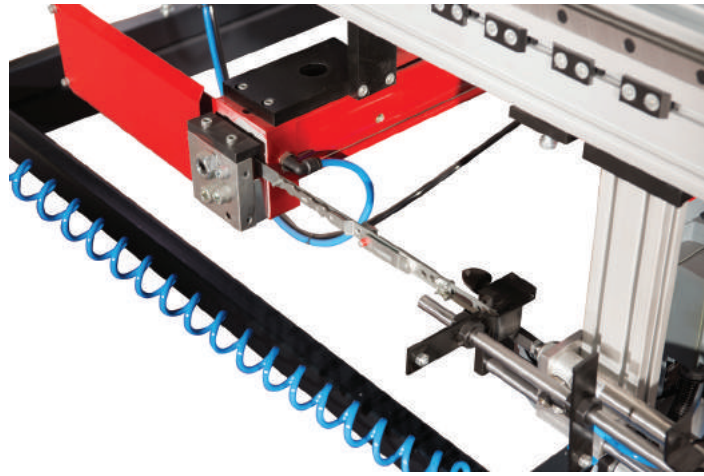

> ÖZELLİKLER

Farklı seri değişik ebatlardaki kapı & pencere kanat profili üzerinde kullanılan tüm çift açılımlı aksesuarlarını; metre, kalem kullanmadan farklı profillere göre ayarlayarak kalıp ve şablon gerektirmeden seri, kaliteli ve standart bir şekilde monte edebilme imkanı sağlar.

> OPSİYONLAR

HD- Yarı Otomatik Ayarlanabilir, Menteşe Delme ve Manuel Menteşe Vidalama Grubu. (Aynı Anda Kullanılabilen Revolve Sistemli Çoklu Şablonlar Tek Açılım Dahil) (2 Kademeli Sistem 3-6 mm için)
EO-FR-S- Aksesuar Rafı (Aydınlatma ve Fonksiyonel Koşe Dönüş Asma Aparatı)

> FEATURES

Used to assembly Tilt&Turn hardware systems on different types, various, sizes of window & door sash profiles. Provides speedy, high quality and standard assembling.

> OPTIONS

HD- Semi automatic adjustable, Hinge drilling and manual hinge screwing group (Multifunctional revolver system)(2 step system for 3-6 mm)
EO-FR-S- Hardware shelf (Lighting and Functional corner element hanger)

WS/130

SASH

ASSEMBLY TABLE

KANAT TOPLAMA MASASI



A Min : 330 A Max : 2500	Min : 3,9 x 16 Max : 4,2 x 38	A min : 30 mm A max : 105 mm B min : 50 mm B max : 125 mm	V : 380 kW : 3 A : 8	6-8 bar 250/lt/syc	250 kg	3250 x 2000 x 2020

WS/131

SASH ASSEMBLY STATION

KANAT TOPLAMA MASASI

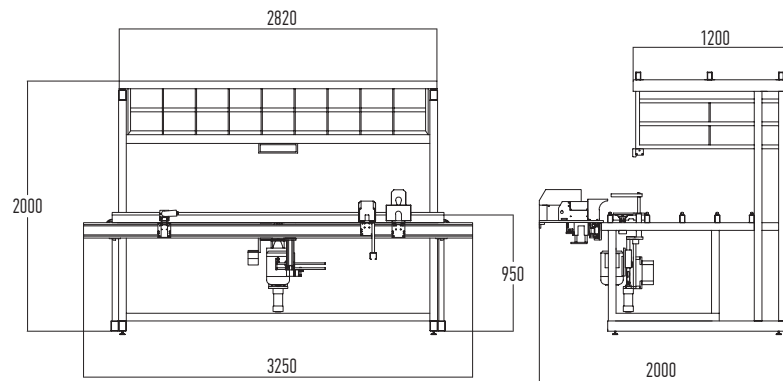
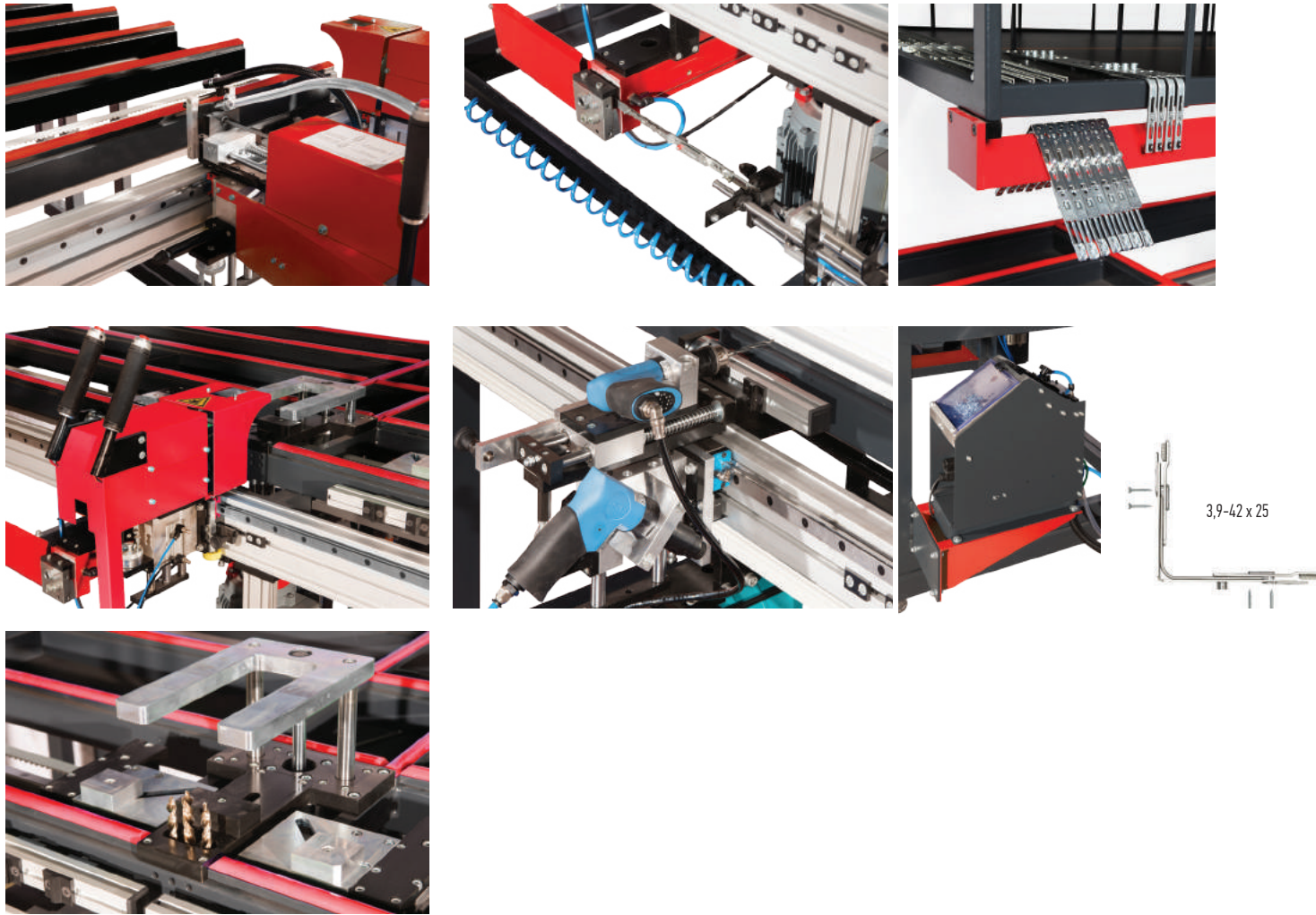

> ÖZELLİKLER

Farklı seri değişik ebatlardaki kapı & pencere kanat profili üzerinde kullanılan tüm çift açılım aksesuarlarını; metre, kalem kullanmadan farklı profillere göre ayarlayarak kalıp ve şablon gerektirmeden seri, kaliteli ve standart bir şekilde monte edebilme imkanı sağlar.

> OPSİYONLAR

ASD- Tam Otomatik Vidalama, Otomatik Vida Besleme Ünitesi (Lazer vida hizalama sistemi)
 TD- Uçlu Kolyeri Delme Grubu (Destek Sacı ile Birlikte) 10*12*10
 HD- Yarı Otomatik Ayarlanabilir, Mentеше Delme ve Manuel Mentеше Vidalama Grubu. (Aynı Anda Kullanılabilen Revolve Sistemli Çoklu Şablonlar Tek Açılım Dahil) (2 Kademeli Sistem 3-6 mm için)
 BC- İspanyollet Kanal Açma Frezesi (12-16 mm)
 EO-FR-S- Aksesuar Rafi (Aydınlatma ve Fonksiyonel Koşe Dönüş Asma Aparatı)

> FEATURES

Used to assembly all Tilt&Turn hardware systems on different types, various, sizes of window & door sash profiles without tape measure and pencil using, without need for molds and templates, provides speedy, high quality and standard assembling.

> OPTIONS

ASD- Full Automatic Screwing, Automatic screw feeding unit, Laser pointer
 TD- Triple handle hole drilling group (with reinforced profile) 10*12*10
 HD- Semi automatic adjustable, Hinge drilling and manual hinge screwing group (Multifunctional revolver system)(2 step system for 3-6 mm)
 BC- Milling tool for espagnolette channel grooving (12-16 mm)
 EO-FR-S- Hardware shelf (Lighting and Functional corner element hanger)

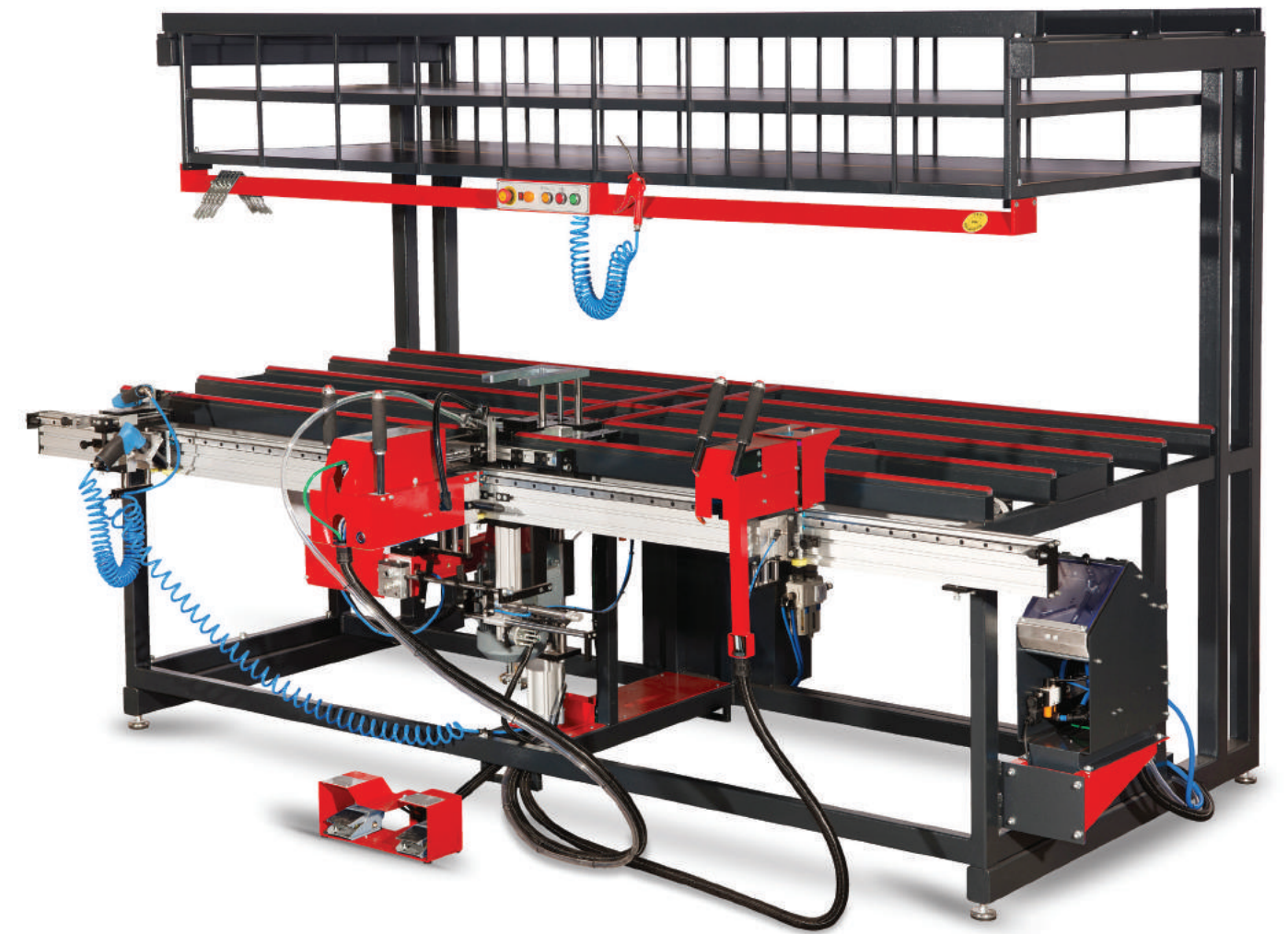

A Min : 330 A Max : 2500	Min : 3,9 x 16 Max : 4,2 x 38	A min : 30 mm A max : 105 mm B min : 50 mm B max : 125 mm	V : 380 kW : 3 A : 8	6-8 bar 250/lt/syc	610 kg	3250 x 2000 x 2020

WS/131 S

SASH ASSEMBLY STATION

KANAT TOPLAMA İSTASYONU

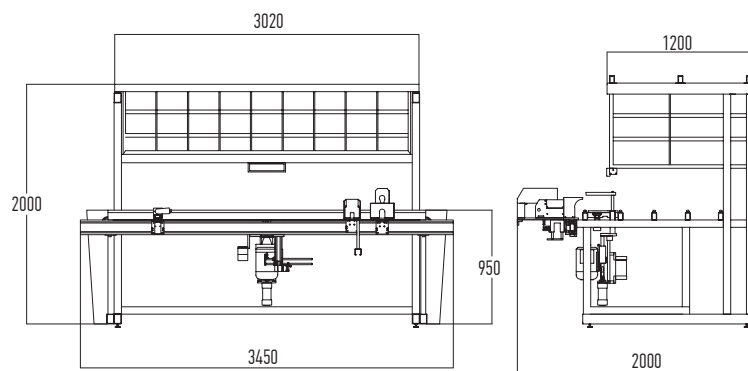
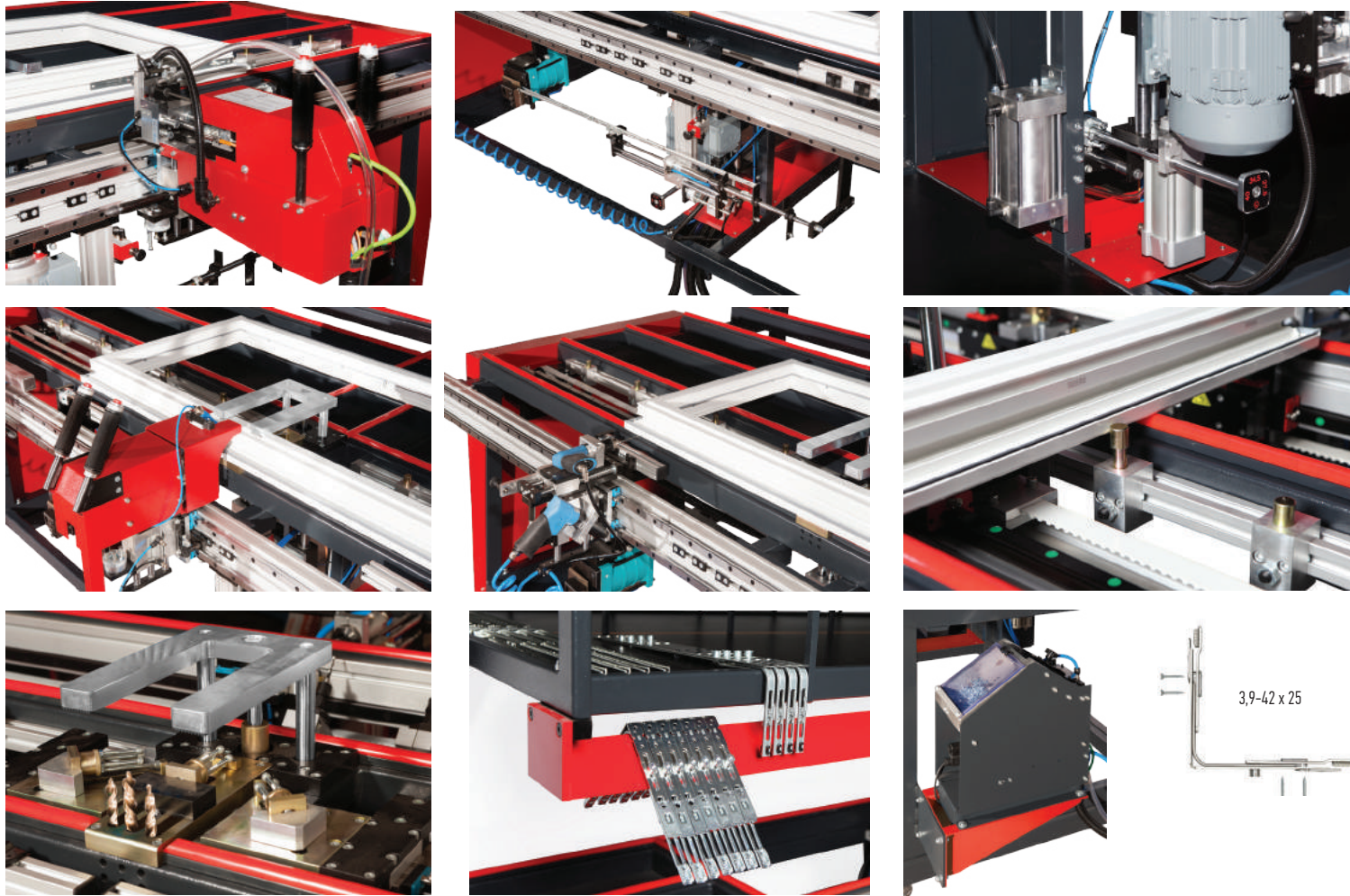

ÖZELLİKLER

Farklı seri değişik ebatlardaki kapı & pencere kanat profili üzerinde kullanılan tüm çift açılım aksesuarlarını; metre, kalem kullanmadan farklı profillere göre ayarlayarak kalıp ve şablon gerektirmeden seri, kaliteli ve standart bir şekilde monte edebilme imkanı sağlar.

OPSIYONLAR

ASD- Çift kademeli tam otomatik vidalama. Otomatik Vida Besleme Ünitesi (Lazer vida hizalama sistemi)
 TD- Hareketli ayarlanabilir ve hava soğutmalı uçlu Kolyeri Delme Grubu (Destek Sacı ile Birlikte)
 HD- Yarı Otomatik Ayarlanabilir, Mentеше Delme ve Manuel Mentеше Vidalama Grubu. (Aynı Anda Kullanılabilen Revolve Sistemli Çoklu Şablonlar Tek Açılım Dahil) (2 Kademeli Sistem 3-6 mm için)
 BC- İspanyollet Kanal Açma Frezesi ve otomatik hava ünitesi (12-16 mm)
 EO-FR-S- Aksesuar Rafi (Aydınlatma ve Fonksiyonel Koşe Donuş Asma Aparatı)

FEATURES

Used to assembly all Tilt&Turn hardware systems on different types, various, sizes of window & door sash profiles without tape measure and pencil using, without need for molds and templates, provides speedy, high quality and standard assembling.

OPTIONS

ASD- Full Automatic Screwing with two steps, Automatic screw feeding unit, Laser pointer
 TD- Movable adjustable triple handle hole drilling group with air cooling (with reinforced profile) 10*12*10
 HD- Semi automatic adjustable, Hinge drilling and manual hinge screwing group (Multifunctional revolver system)(2 step system for 3-6 mm)
 BC- Milling tool for espagnolette channel grooving and air unit (12-16 mm)
 EO-FR-S- Hardware shelf (Lighting and Functional corner element hanger)

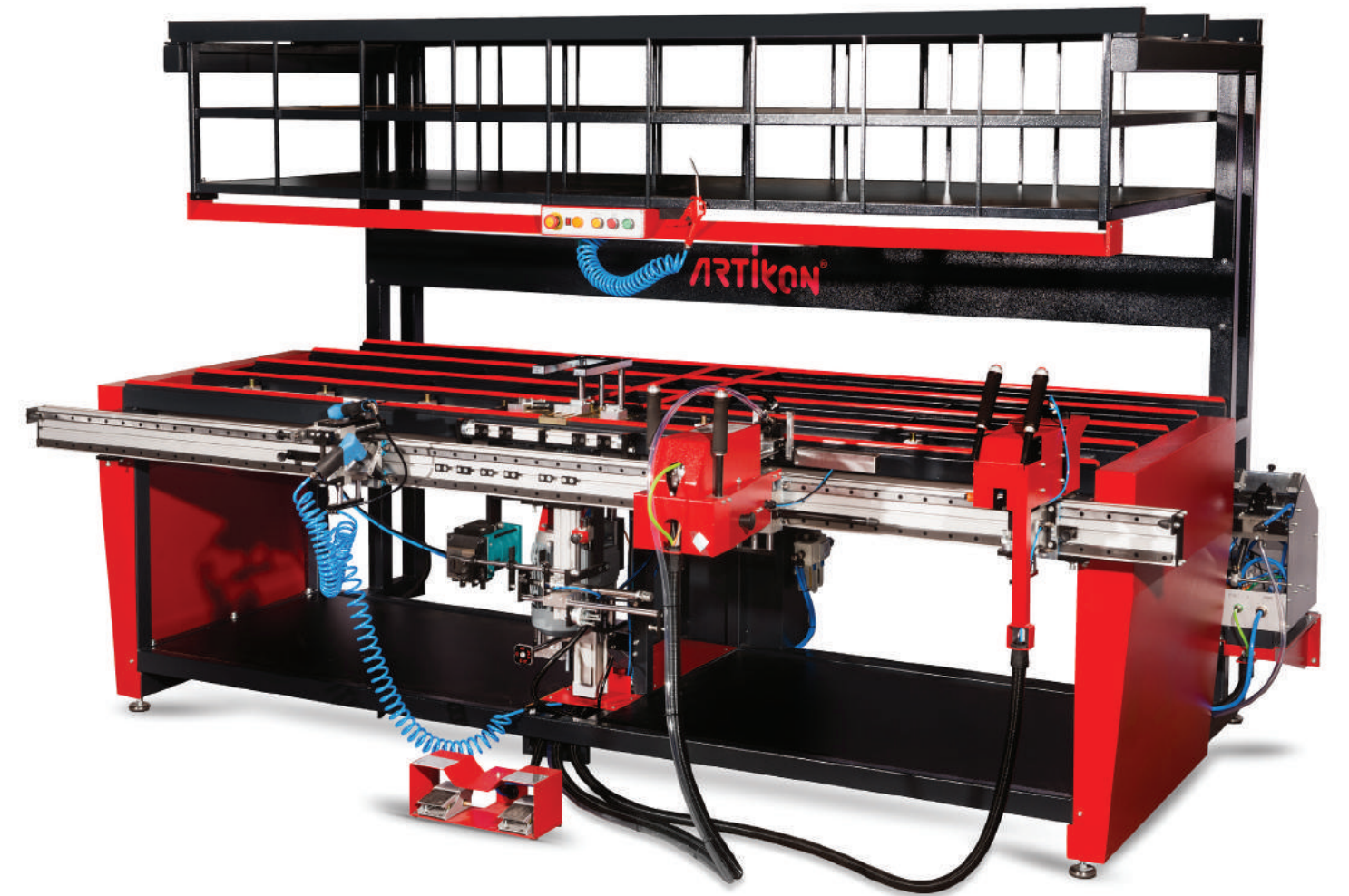

A Min : 330 A Max : 2520	Min : 3,9 x 16 Max : 4,2 x 38	A min : 30 mm A max : 100 mm B min : 50 mm B max : 125 mm	V : 380 kW : 3 A : 8	6-8 bar 250/t/syc	850 kg	3450 x 2000 x 2020

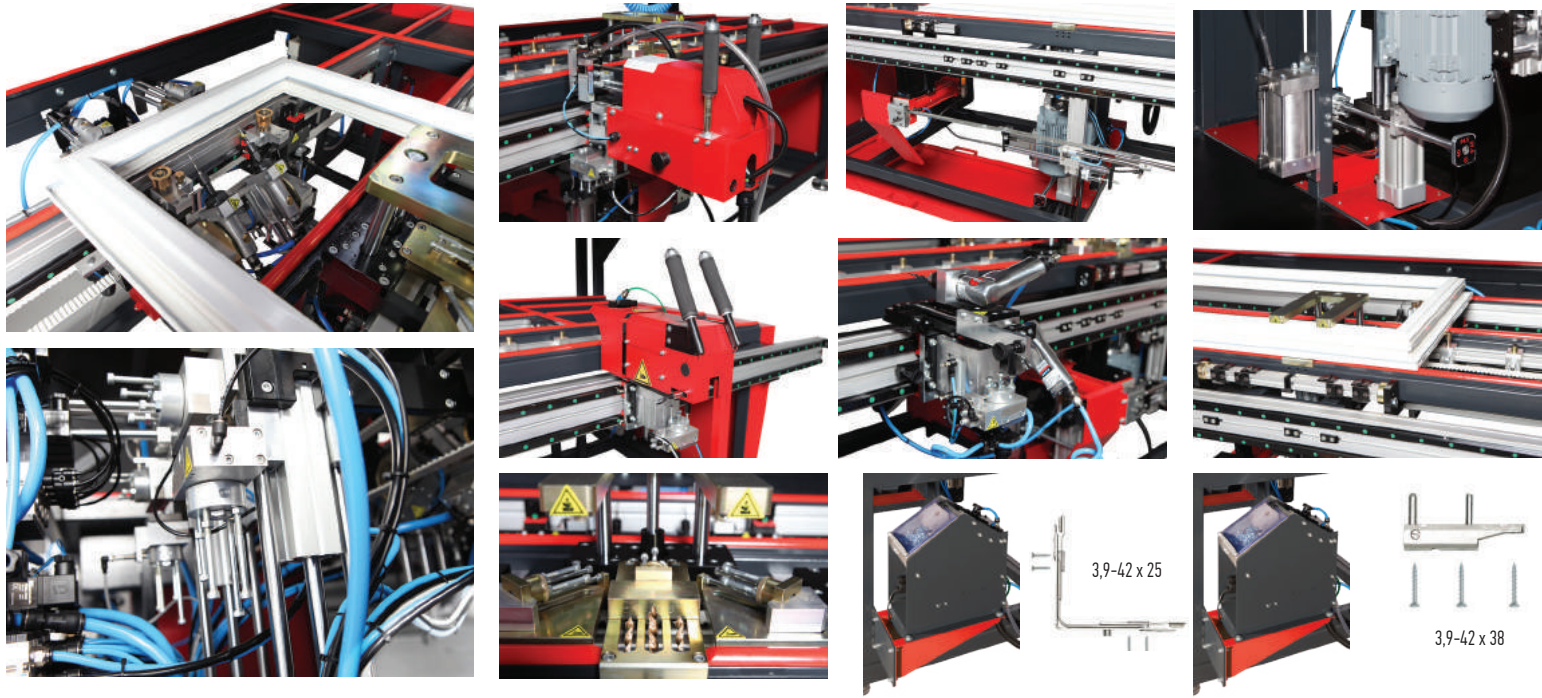

WS/134 SW

SASH ASSEMBLY STATION

WATER SLOT DRILLING

KANAT TOPLAMA İSTASYONU
SU TAHLİYELİ

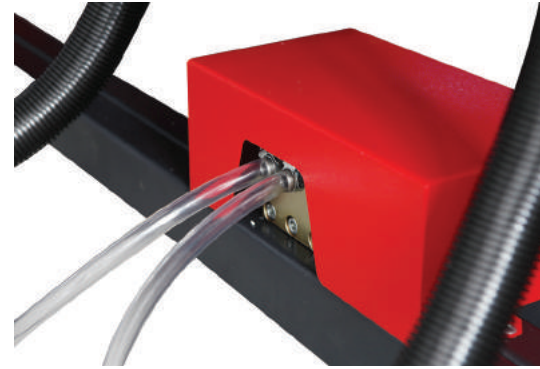
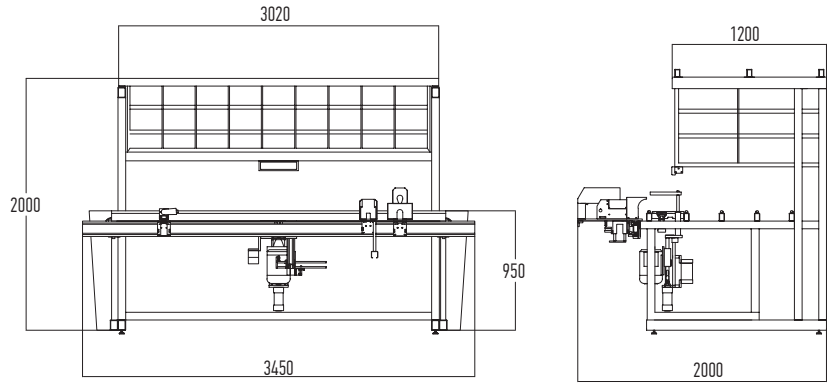

ÖZELLİKLER

Farklı seri değişik ebatlarda kapı & pencere kanat profili üzerinde kullanılan tüm tek açılım, çift açılım, çift kanat ve volswagen sürme aksesuarlarını; metre, kalem kullanmadan ayar, kalıp ve şablon gerektirmeden, seri, kaliteli ve standart bir şekilde monte edebilme imkanı sağlar.
Farklı seri değişik ebatlarda kapı & pencere kanat profillerini ekrandan seçerek revolver sistemi ile otomatik ayar imkanı.
Her türlü açılım ve aksesuar montajı için uyumlu

>

OPSİYONLAR

ASD- Çift kademeli tam otomatik vidalama ((hem 3,9-42x25 vida, hem 3,9-42x38 vida için uyumludur). İkili Otomatik Vida Besleme Ünitesi (Lazer vida hizalama sistemi)
TD- Hareketli ayarlanabilir ve hava soğutmalı üçlü Kolyeri Delme Grubu (Destek Sacı ile Birlikte)
HD- Yan Otomatik Ayarlanabilir, Mentеше Delme ve Manuel Mentеше Vidalama Grubu (Aynı Anda Kullanılabilen Revolve Sistemli Çoklu Şablonlar Tek Açılım Dahil) (2 Kademeli Sistem 3-6 mm için)
BC- İspanyollet Kanal Açma Frezesi ve otomatik hava ünitesi (12-16 mm)
EO-FR-S- Uç Bölmeli Aksesuar Rafi (Aydınlatma ve Fonksiyonel Köşe Dönüş Asma Aparatı)
SW - Tam Otomatik 4'lü Su tahliye Sistemi (İç ve Dış Aynı Anda Su Tahliye Açma)

FEATURES

Used to assembly all Tilt&Turn hardware systems on different types, various, sizes of window & door sash profiles without tape measure and pencil using, without need for molds and templates, provides speedy, high quality and standard assembling.
Used to assembly all Tilt&Turn hardware systems on different types, various, sizes of window & door sash profiles. Adjustment make by revolver automatic system after selected on touch screen.

> Suitable for all kind of Tilt & Turn and accessories assembling

OPTIONS

ASD- Full Automatic Screwing with two steps. (for 3,9-42x25 screw, & for 3,9-42x38 screws). Double Automatic screw feeding unit, Laser pointer
TD- Movable adjustable triple handle hole drilling group with air cooling (with reinforced profile) 10*12*10
HD- Semi automatic adjustable, Hinge drilling and manual hinge screwing group (Multifunctional revolver system)(2 step system for 3-6 mm)
BC- Milling tool for espagnolette channel grooving and air unit (12-16 mm)
EO-FR-S- Triple hardware shelf (Lighting and Functional corner element hanger)
SW - Full automatic water slot drilling system with 4 motors (Inside and outside water slot channel opening)

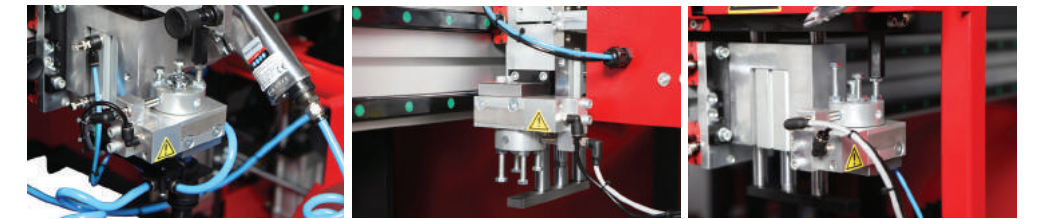
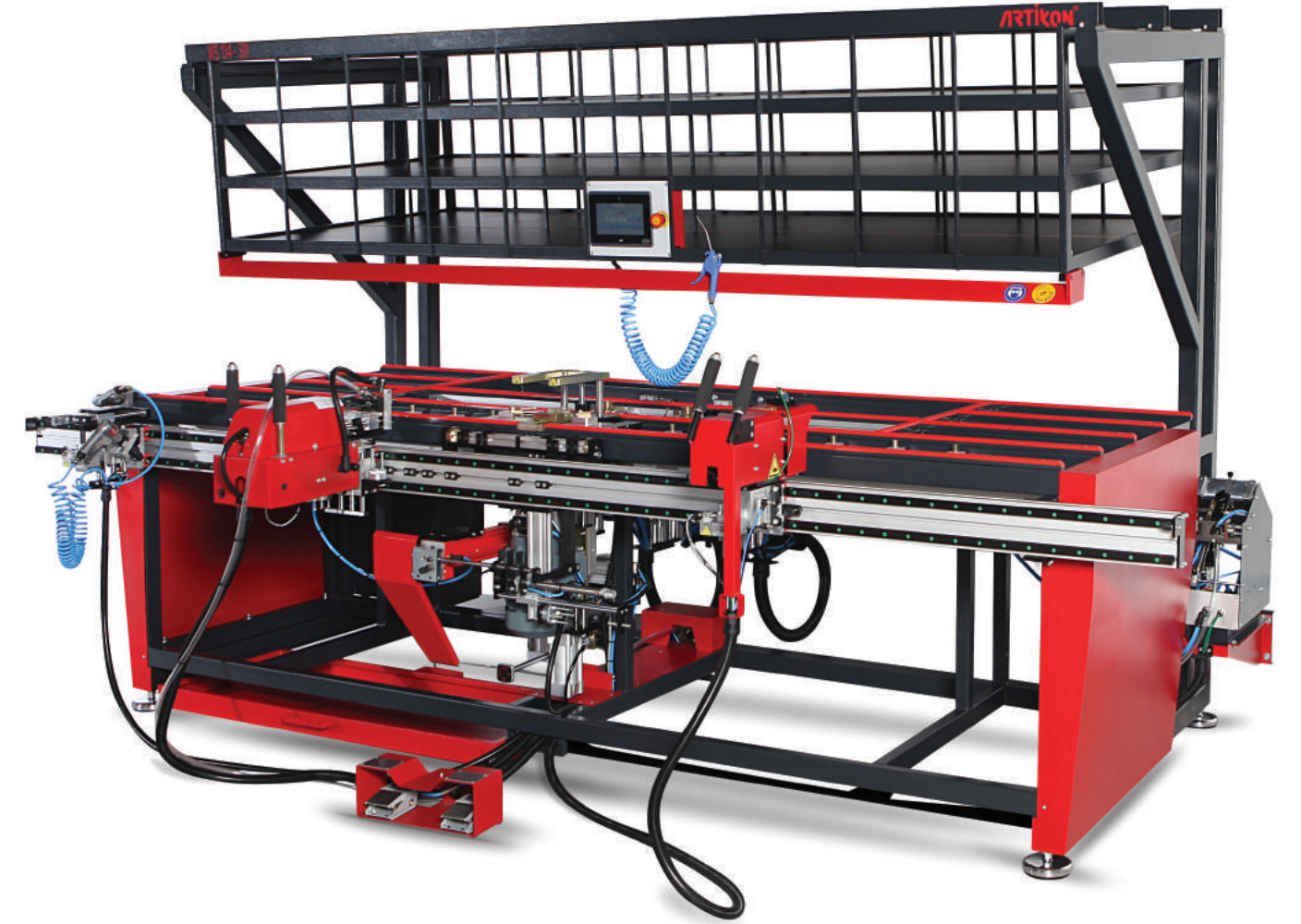

Su Tahliye / Slot Water	Pencere / Window			V : 380	6-8 bar 250/lt/syc	1030 kg	3450 x 2000 x 2020
A Min : 330 A Max : 1280	A Min : 330 A Max : 2520	Min : 3,9 x 16 Max : 4,2 x 38	A min : 30 mm A max : 100 mm B min : 50 mm B max : 125 mm	kW : 3 A : 8			

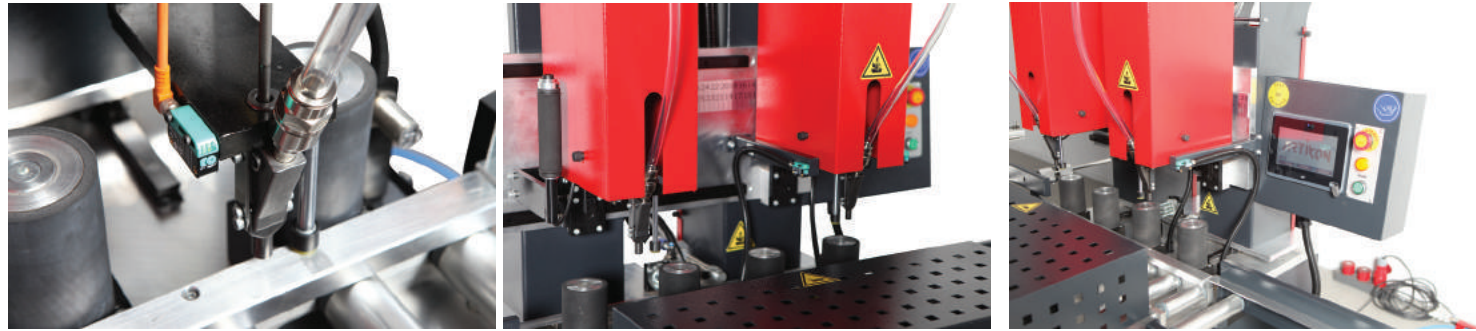
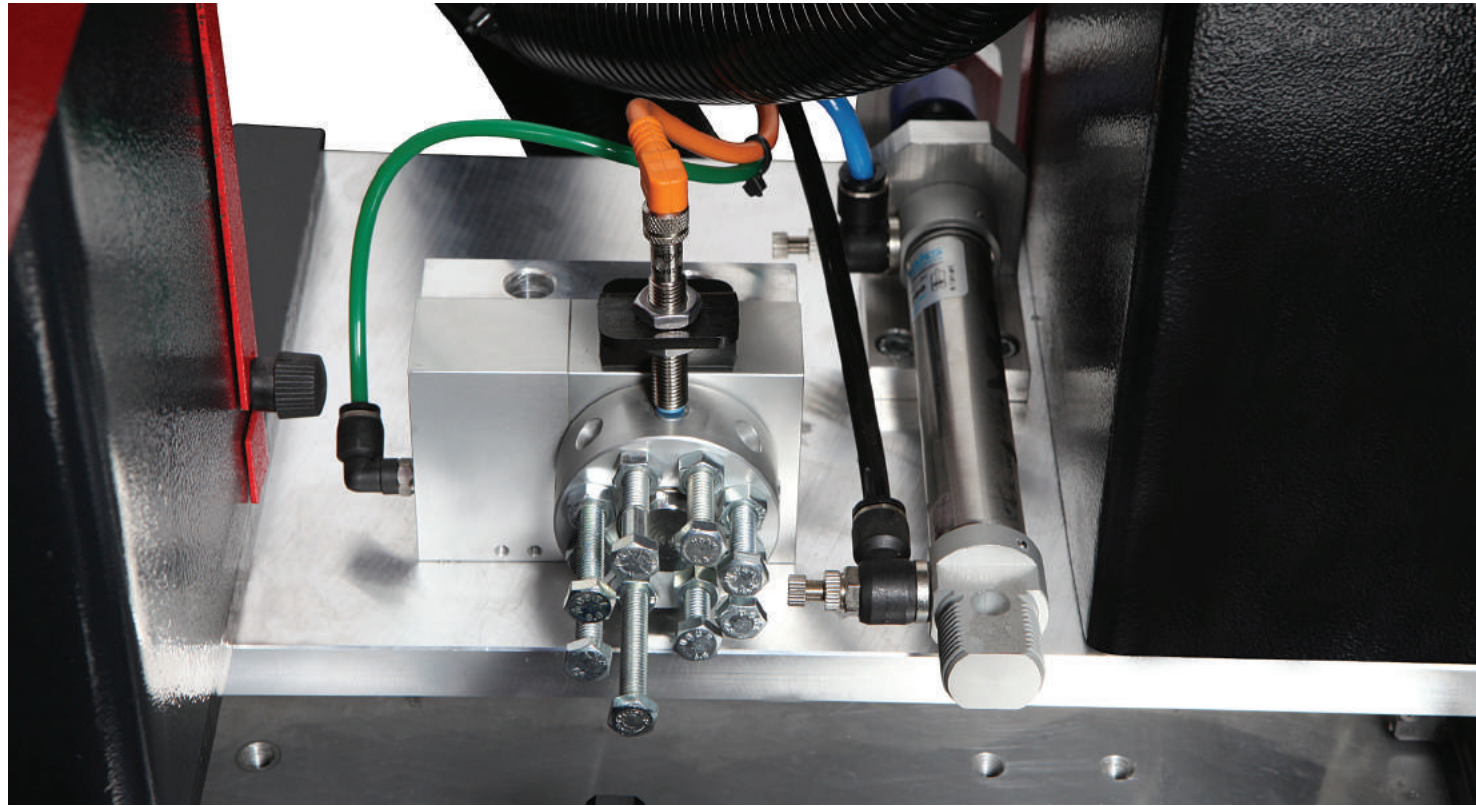

SD/206

FULL AUTOMATIC DOUBLE HEAD SCREWDRIVER MACHINE

TAM OTOMATİK ÇİFT KAFA
VİDALAMA MAKİNASI



> ÖZELLİKLER

- Ölçü girmeden sensör ile otomatik vida arası mesafe ölçümü
- Aynı anda 2 vida atabilme
- Otomatik vida boşaltma
- İşlem bitince otomatik ürün boşaltan çıkış konveyör ve masası
- 8 farklı profil genişliğine göre vida atabilme özelliği
- Tam otomatik PLC kontrollü havalı vida besleme ünitesi
- Vidalama işlemi bittikten sonra otomatik stop
- Hatalı kullanımı önleyici güvenlik sensörleri
- Özel vida yükseklik ayar sensörü
- Destekli profil dayama
- Ekrandan manuel vida besleme
- Ortalama vidalama hızı: 1,7 sn/adet
- Çene dayama sistemi ile uzun ömürlü çalışma
- Ekrandan seçerek otomatik revolver sistemi ile 8 farklı profil ölçülerine göre vida atabilme özelliği.

> FEATURES

- Automatic determination screw position with sensor
- Two screws at the same time
- Automatic recharge the screwdriver
- Discharge of product after finish
- Possibility of screwing for 8 different profile width
- Full automatic PLC controlled screw feeding unit
- Automatic stop after screwing
- Protective sensor to prevent faulty use
- Height adjustment sensor for special screws
- Profile backing support
- Manual screw feeding from screen
- Average screwing speed: 1,7 sec/pcs
- Long term using for screwing head by protector
- Easy adjustment possibility for 8 different sizes of profiles by revolver system after selected on touch screen for screwing

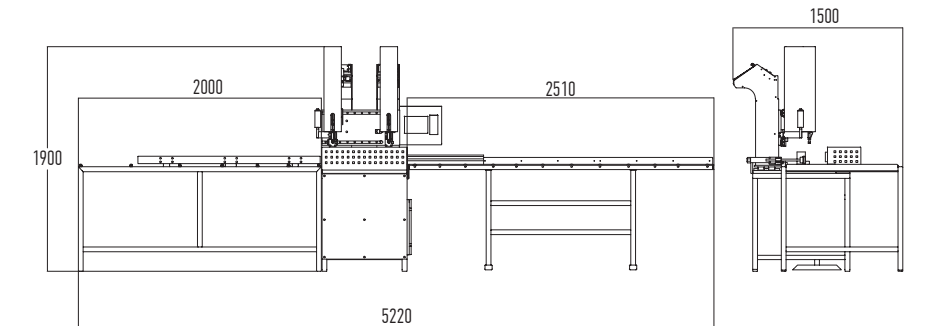

A min : 40 mm A max : 160 mm B min : 40 mm B max : 165 mm	Min : 3,9 x 16 Max : 4,2 x 38	6-8 bar 32/t/syc	340 kg	1250 x 1100 x 1950 2550 x 1450 x 1150	V : 220 kW : 1 Hz : 50

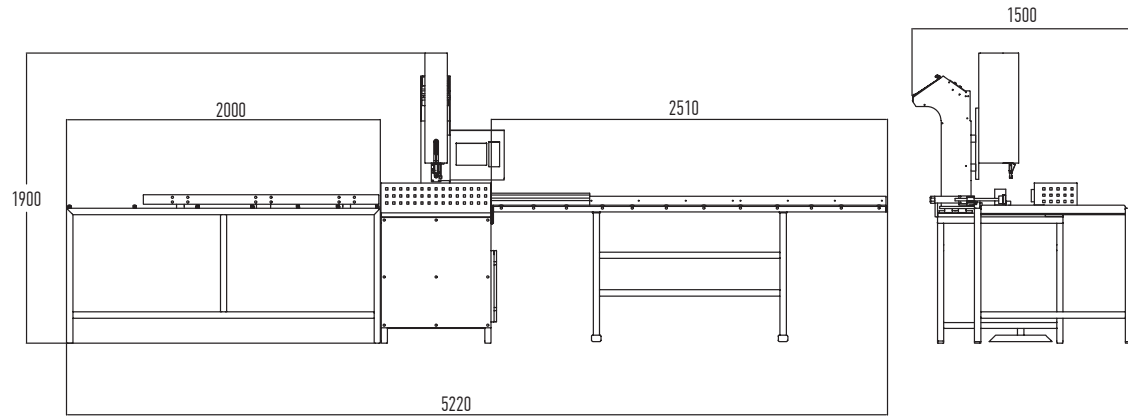
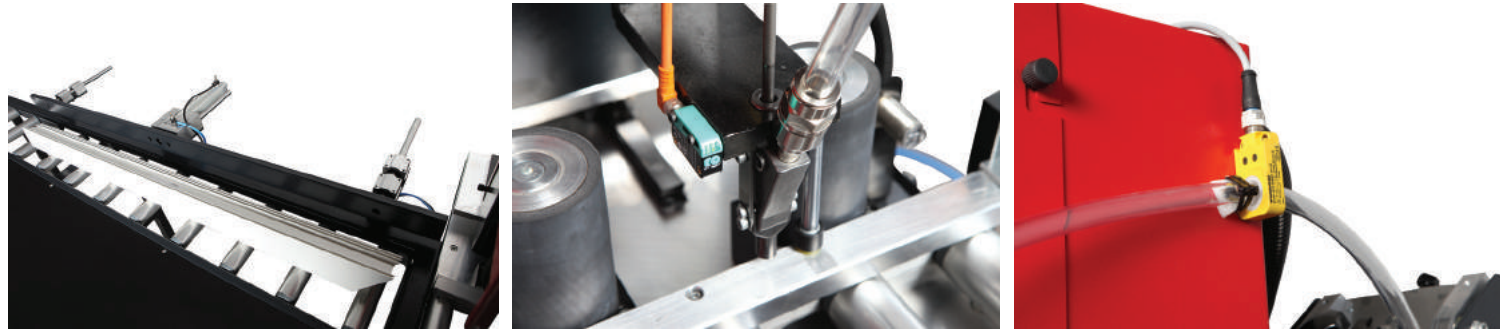
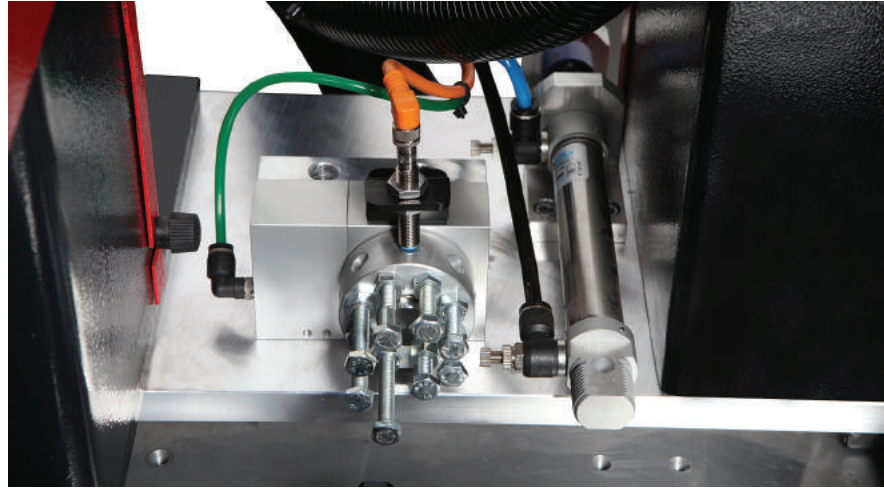

> ÖZELLİKLER

- İki vida arası mesafe ölçü ayarı
- Otomatik vida boşaltma
- İşlem bitince otomatik ürün boşaltan çıkış konveyör ve masası
- 8 farklı profil genişliğine göre vida atabilme özelliği
- Tam otomatik PLC kontrollü havalı vida besleme ünitesi
- Vidalama işlemi bittikten sonra otomatik stop
- Hatalı kullanımı önleyici güvenlik sensörleri
- Özel vida yükseklik ayar sensörü
- Destekli profil dayama
- Ekran üzerinden manuel vida besleme
- Ortalama vidalama hızı: 1,7 sn/adet
- Çene dayama sistemi ile uzun ömürlü çalışma
- Ekran üzerinden seçerek otomatik revolver sistemi ile 8 farklı profil ölçülerine göre vida atabilme özelliği.

> FEATURES

- Automatic determination screw position with sensor
- Automatic recharge the screwdriver
- Discharge of product after finish
- Possibility of screwing for 8 different profile width
- Full automatic PLC controlled screw feeding unit
- Automatic stop after screwing
- Protective sensor to prevent faulty use
- Height adjustment sensor for special screws
- Profile backing support
- Manual screw feeding from screen
- Average screwing speed: 1,7 sec./pcs
- Long term using for screwing head by protector
- Easy adjustment possibility for 8 different sizes of profiles by revolver system after selected on touch screen for screwing.

SD/205 FULL AUTOMATIC SINGLE HEAD SCREWDRIVER MACHINE

TAM OTOMATİK TEK KAFA
VİDALAMA MAKİNASI



A min : 40 mm A max : 160 mm B min : 40 mm B max : 165 mm	Min : 3,9 x 16 Max : 4,2 x 38	6-8 bar 32/lt/syc	340 kg	1250 x 1100 x 1950 2550 x 1450 x 1150	V : 220 kW : 1 Hz : 50

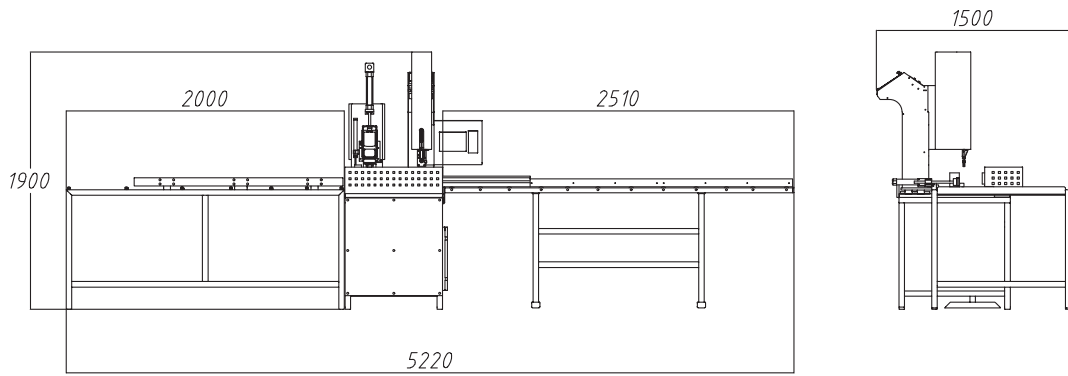
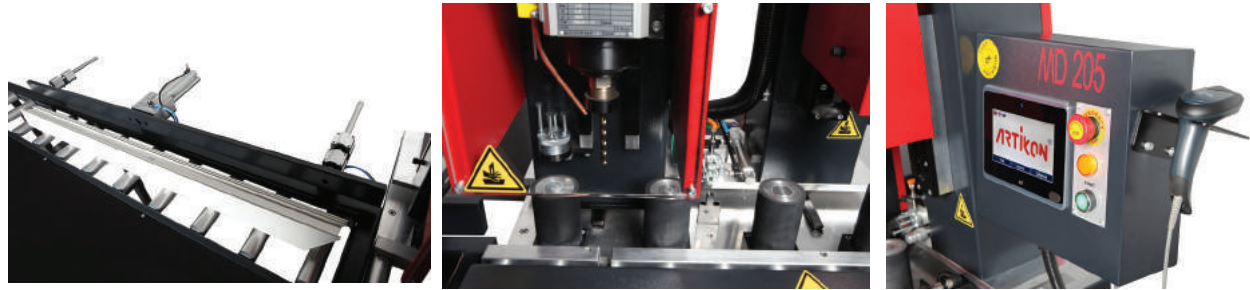
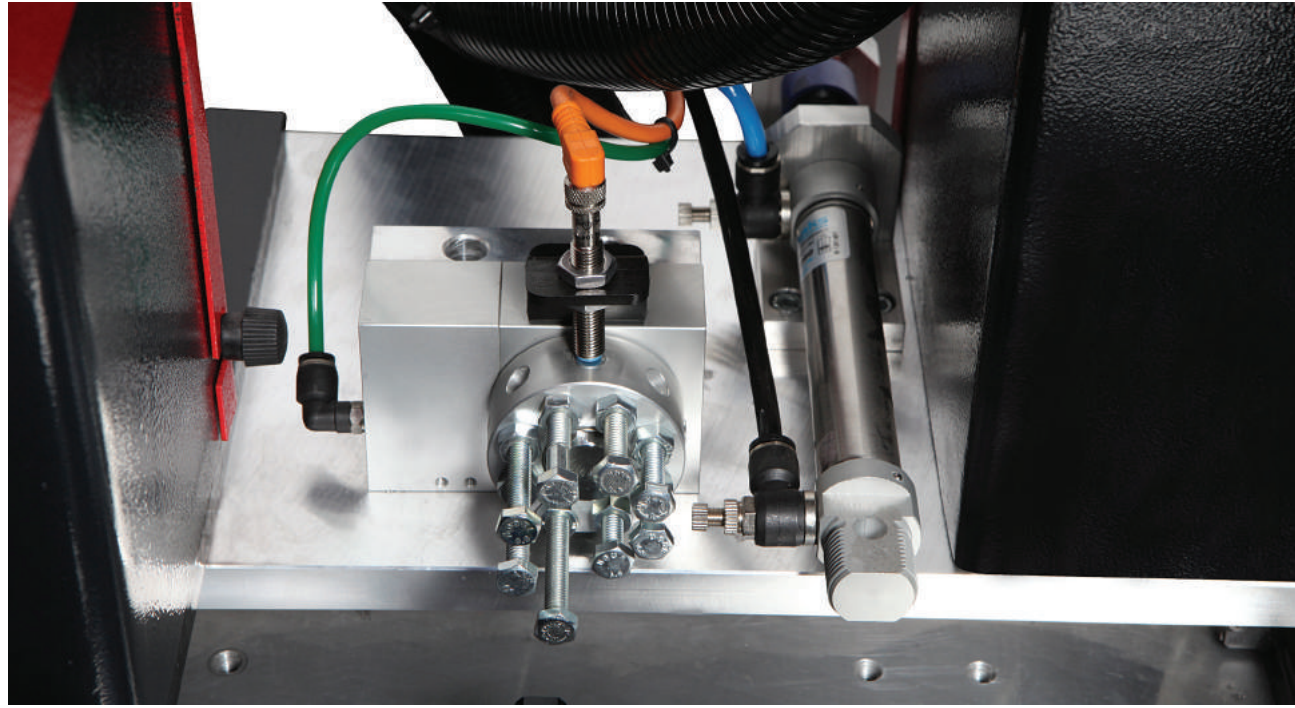

> ÖZELLİKLER

- İki vida arası mesafe ölçü ayarı
- Otomatik vida boşaltma
- İşlem bitince otomatik ürün boşaltan çıkış konveyör ve masası
- 8 farklı profil genişliğine göre vida atabilme özelliği
- Tam otomatik PLC kontrollü havalı vida besleme ünitesi
- Vidalama işlemi bittikten sonra otomatik stop
- Hatalı kullanımı önleyici güvenlik sensörleri
- Özel vida yükseklik ayar sensörü
- Destekli profil dayama
- Ekrandan manuel vida besleme
- Ortalama vidalama hızı: 1,7 sn/adet
- Çene dayama sistemi ile uzun ömürlü çalışma
- Ekrandan seçerek otomatik revolver sistemi ile 8 farklı profil ölçülerine göre vida atabilme özelliği.
- Profil ölçüsü ile (ekrandan manuel veya barkod ile) montaj deliği açar.

> FEATURES

- Automatic determination screw position with sensor
- Automatic recharge the screwdriver
- Discharge of product after finish
- Possibility of screwing for 8 different profile width
- Full automatic PLC controlled screw feeding unit
- Automatic stop after screwing
- Protective sensor to prevent faulty use
- Height adjustment sensor for special screws
- Profile backing support
- Manual screw feeding from screen
- Average screwing speed: 1,7 sec./pcs
- Long term using for screwing head by protector
- Easy adjustment possibility for 8 different sizes of profiles by revolver system after selected on touch screen for screwing.
- Montage drilling possibility with profile size (manual from screen or from barcode).

SD/205 MD

FULL AUTOMATIC SINGLE HEAD SCREWDRIVER MACHINE AND MONTAGE DRILLING

TAM OTOMATİK TEK KAFA VİDALAMA MAKİNASI
MONTAJ DELMELİ



A min : 40 mm A max : 160 mm B min : 40 mm B max : 165 mm	Min : 3,9 x 16 Max : 4,2 x 38	6-8 bar 32/lt/syc	407 kg	1250 x 1100 x 1950 2550 x 1450 x 1150	V : 220 kW : 1,1 Hz : 50 3000 rpm

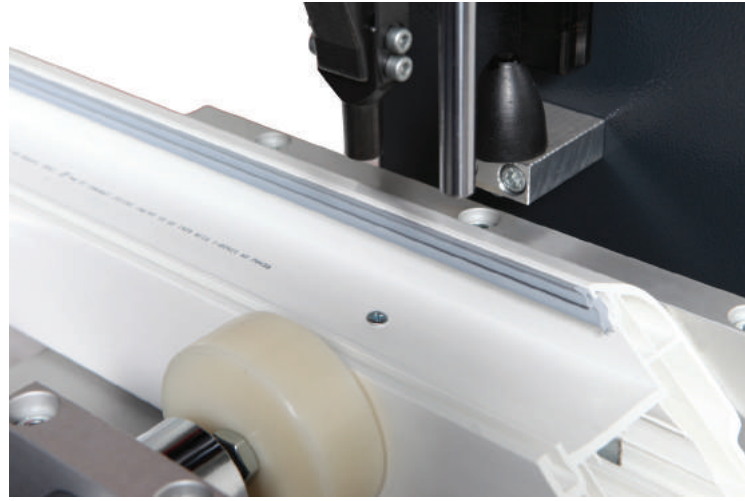
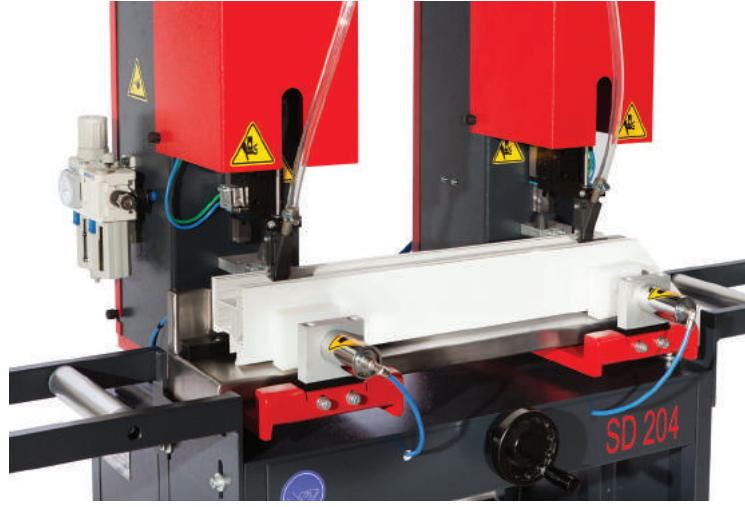

SD/204 AUTOMATIC DOUBLE HEAD VERTICAL SCREWDRIVER MOVABLE

İKİLİ OTOMATİK DİKEY
VİDALAMA MAKİNASI HAREKETLİ

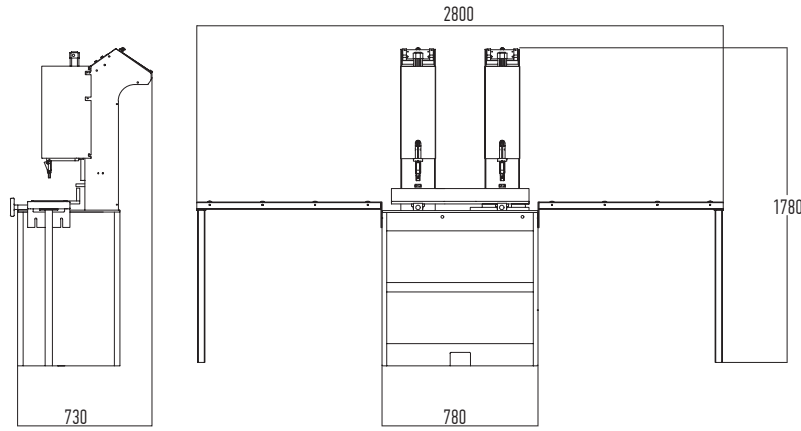

> ÖZELLİKLER

- Havalı otomatik vida besleme ünitesi
- Basma kavramalı otomatik vidalama
- Vidalama işlemi bittikten sonra otomatik stop
- Hatasız vidalama için ayak pedallı kumanda
- Özel vida yükseklik ayar swici
- Vidalama esnasında profili otomatik sıkıştırma
- Ayarlanabilir destekli profil dayama mesafesi
- Uzun ömürlü uç kullanımı ve kolay değiştirme imkanı
- Ortalama vidalama hızı: 1,7 sn/adet

> FEATURES

- Pneumatic unit of automatic screw feeding
- Pedal control of automatic screwing
- Automatic stop after screwing
- Foot pedal control for flawless screwing
- Height adjustment sensor for special screws
- Automatic clamping of profile during screwing
- Adjustable range stops supporting profile
- Durable use of bit and easy change possibility
- Average screwing speed: 1,7 sec/pcs

A min : 40 mm A max : 120 mm B min : 40 mm B max : 120 mm	Min : 3,9 x 16 Max : 4,2 x 38	6-8 bar 32/lt/syc	190 kg	1250 x 1100 x 1950

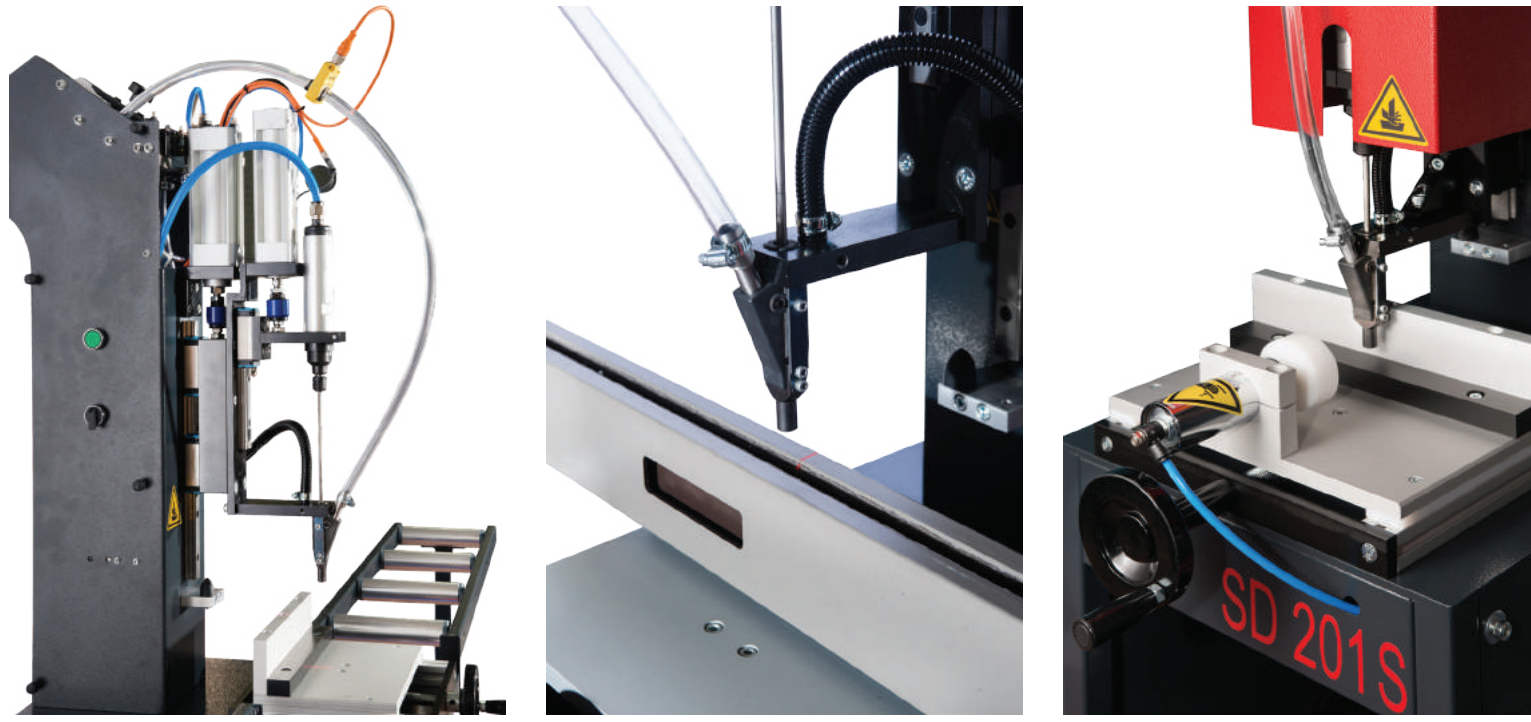

> ÖZELLİKLER

- Tam otomatik PLC kontrollü havalı vida besleme ünitesi
- Basma kavramalı otomatik vidalama
- Elektrikli vida boşaltma özelliği
- Vida geçiş sensörü
- Lazer vida hizalama sistemi
- Vidalama işlemi bittikten sonra otomatik stop
- Hatasız vidalama için ayak pedallı kumanda
- Hatalı kullanımı önleyici güvenlik swichi
- Özel vida yükseklik ayar swichi
- Vidalama esnasında profili otomatik sıkıştırma
- Ayarlanabilir destekli profil dayama mesafesi
- Uzun ömürlü uç kullanımı ve kolay değiştirme imkanı
- Ortalama vidalama hızı: 1,7 sn/adet

> FEATURES

- Full automatic PLC controlled screw feeding unit
- Pedal control of automatic screwing
- Automatic recharge the screwdriver
- Sensor for screw recognition
- Laser pointer
- Automatic stop after screwing
- Foot pedal control for flawless screwing
- Protective sensor to prevent faulty use
- Height adjustment sensor for special screws
- Automatic clamping of profile during screwing
- Adjustable range stops supporting profile
- Durable use of bit and easy change possibility
- Average screwing speed: 1,7 sec./pcs

SD/201 S

AUTOMATIC SCREWDRIVER

OTOMATİK DİKEY VIDALAMA MAKİNASI

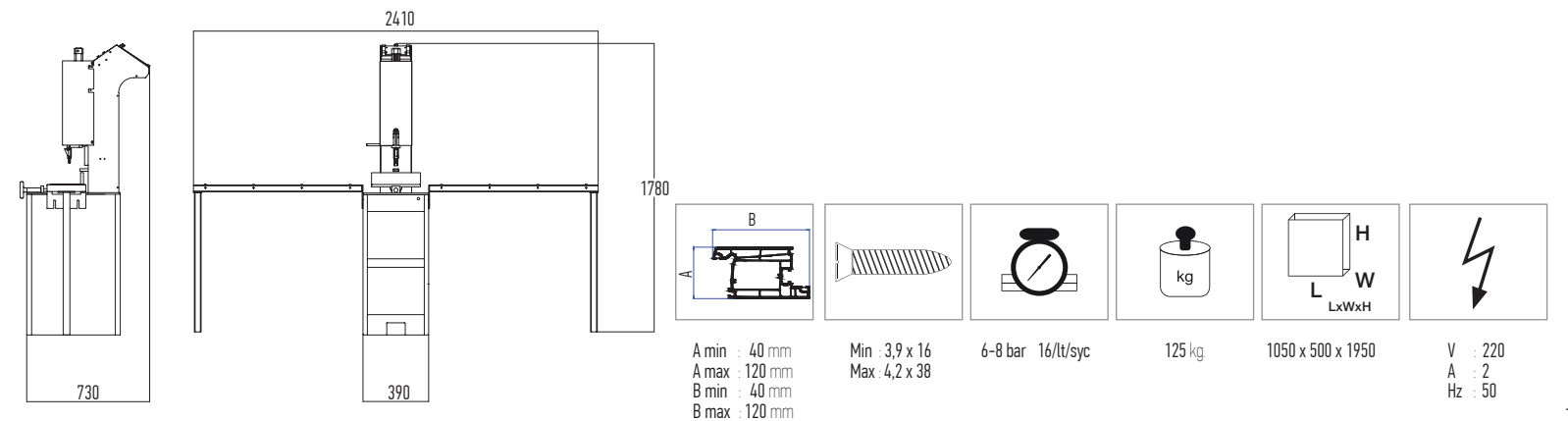

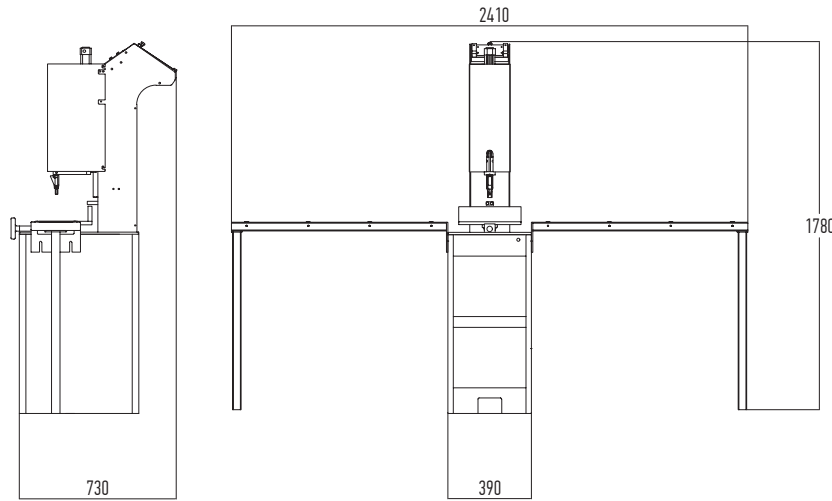
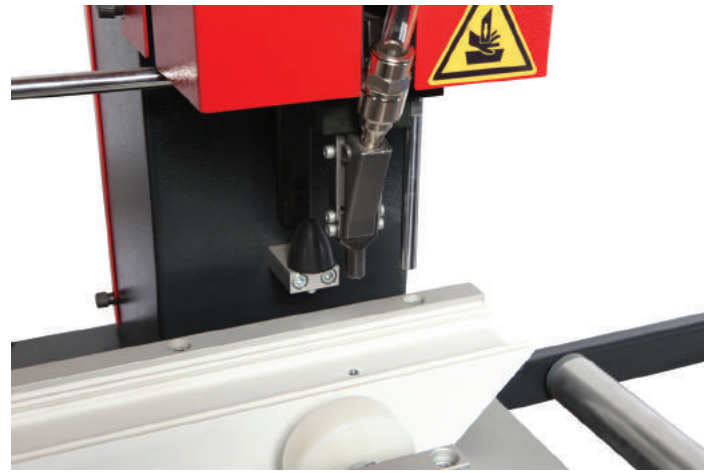
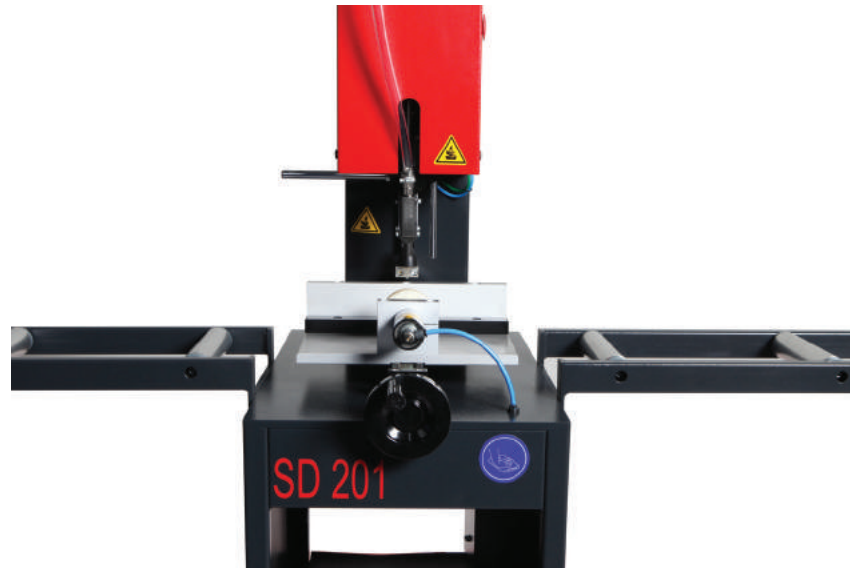

> ÖZELLİKLER

- Havalı otomatik vida besleme ünitesi
- Basma kavramalı otomatik vidalama
- Vidalama işlemi bittikten sonra otomatik stop
- Özel vida yükseklik ayar swici
- Vidalama esnasında profil otomatik sıkıştırma
- Ayarlanabilir destekli profil dayama mesafesi
- Uzun ömürlü uç kullanımı ve kolay değiştirme imkanı
- Ortalama vidalama hızı: 1,7 sn/adet

> FEATURES

- Pneumatic unit of automatic screw feeding
- Pedal control of automatic screwing
- Automatic stop after screwing
- Height adjustment sensor for special screws
- Automatic clamping of profile during screwing
- Adjustable range stops supporting profile
- Uzun ömürlü uç kullanımı ve kolay değiştirme imkanı
- Ortalama vidalama hızı: 1,7 sn/adet

SD/201 AUTOMATIC SCREWDRIVER OTOMATİK DIKEY VİDALAMA MAKİNASI



A min : 40 mm A max : 120 mm B min : 40 mm B max : 120 mm	Min : 3,9 x 16 Max : 4,2 x 38	6-8 bar 16/t/syc	110 kg	1050 x 500 x 1950

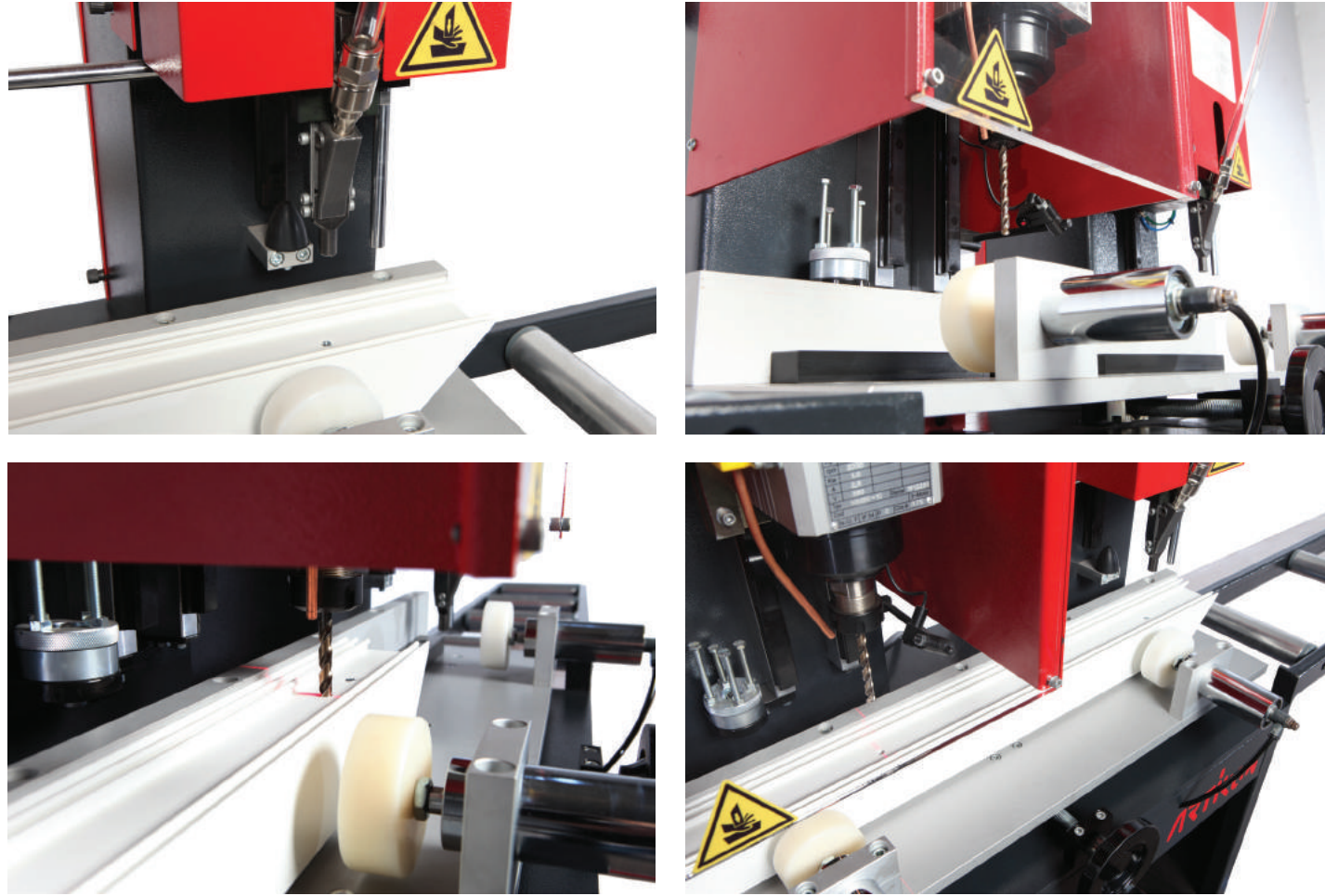

SD/201 MD AUTOMATIC SCREWDRIVER & MONTAGE DRILLING

OTOMATİK DİKEY VİDALAMA MAKİNASI
MONTAJ DELMELİ

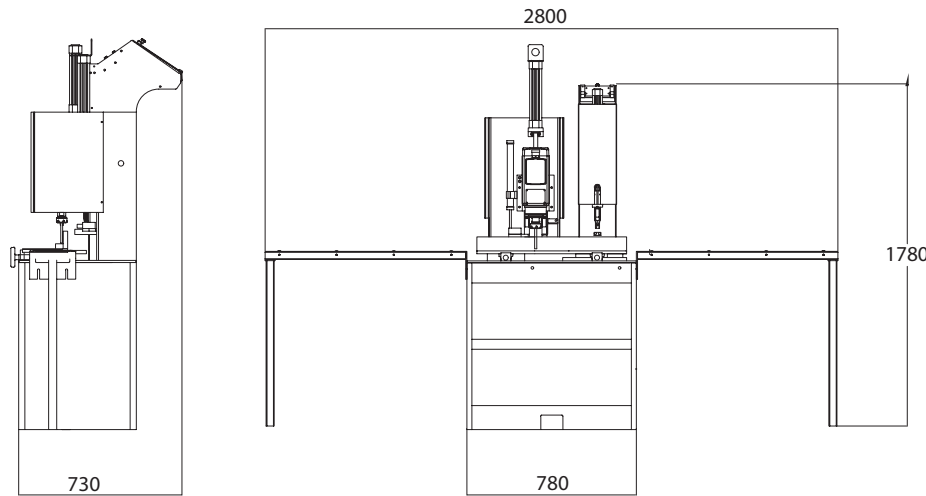

> ÖZELLİKLER

- Havali otomatik vida besleme ünitesi
- Basma kavramalı otomatik vidalama
- Vidalama işlemi bittikten sonra otomatik stop
- Özel vida yükseklik ayar swici
- Vidalama esnasında profili otomatik sıkıştırma
- Ayarlanabilir destekli profil dayama mesafesi
- Uzun ömürlü uç kullanımı ve kolay değişime imkanı
- Montaj deliği açma imkanı
- Ortalama vidalama hızı: 1,7 sn/adet

> FEATURES

- Pneumatic unit of automatic screw feeding
- Pedal control of automatic screwing
- Automatic stop after screwing
- Height adjustment sensor for special screws
- Automatic clamping of profile during screwing
- able range stops supporting profile
- Uzun ömürlü uç kullanımı ve kolay değişime imkanı
- Possibility to drill the montage hole
- Ortalama vidalama hızı: 1,7 sn/adet



V : 380 Hz : 50 kW : 1.1 3000 rpm	A min : 40 mm A max : 160 mm B min : 40 mm B max : 130 mm	Min : 3,9 x 16 Max : 4,2 x 38	6-8 bar 16/lit/syc	185 kg	1050 x 500 x 1950

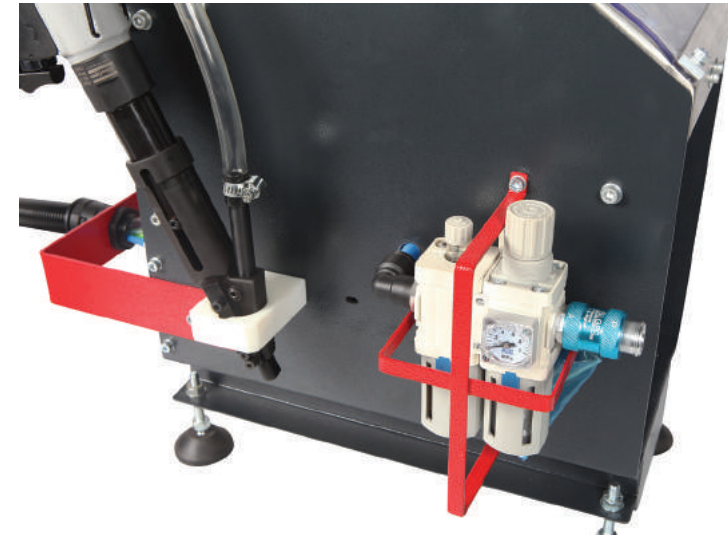
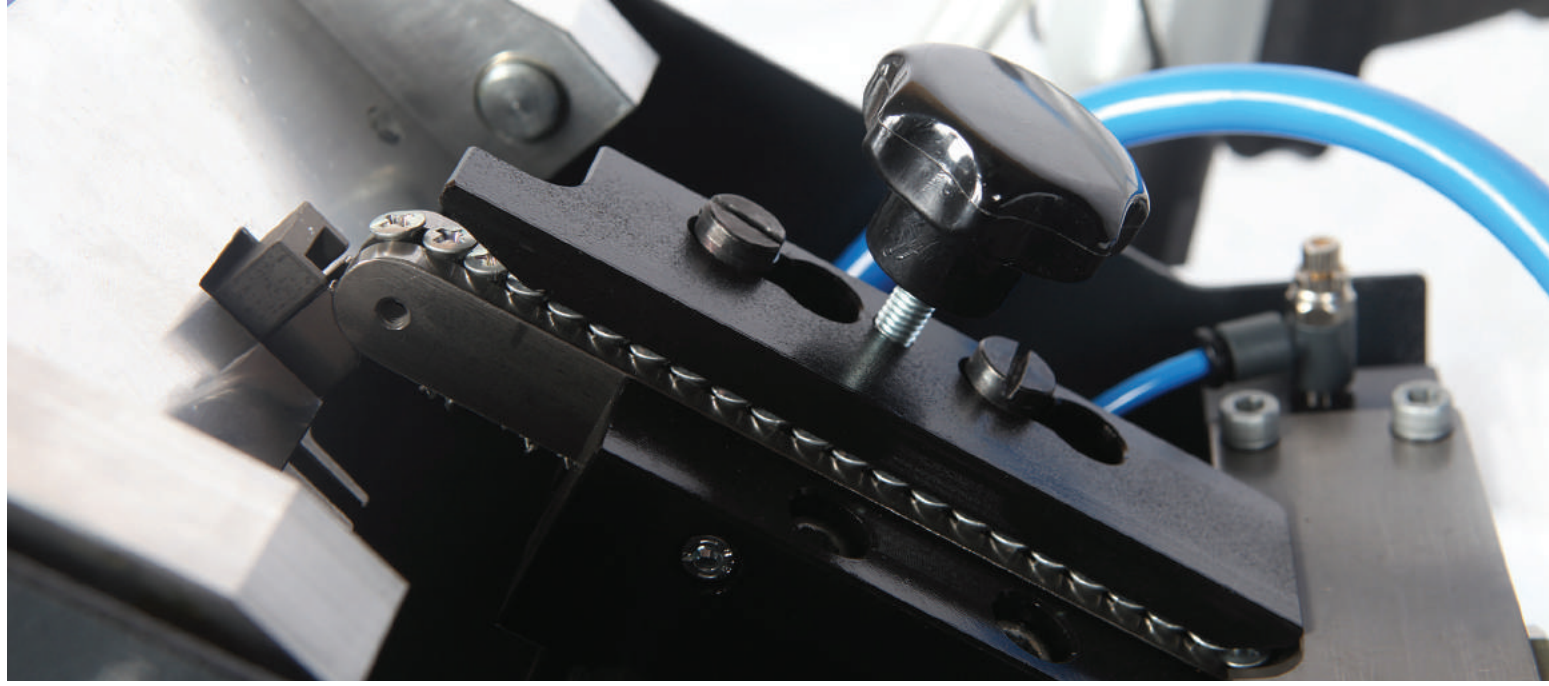

SD/101 MANUAL SCREWDRIVER AND AUTOMATIC FEEDING UNIT

MANUEL VİDALAMA VE OTOMATİK
BESLEME ÜNİTESİ

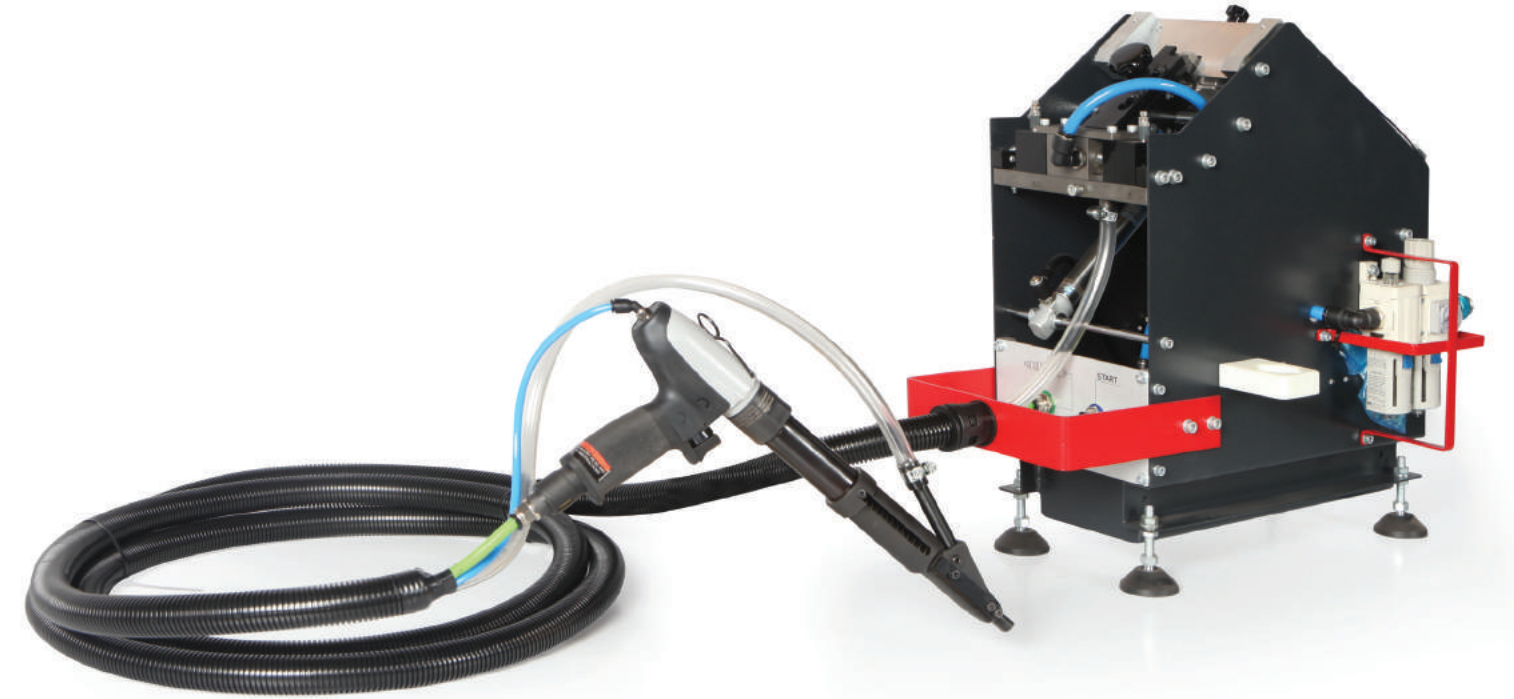

> ÖZELLİKLER

Kapı ve pencere üretiminde kullanılan destek sacı, ispanyolet vidaları ve menteşe vidalarını sıkma işlemi yapar.
Havalı otomatik vida besleme ünitesi
Hızlı ve seri kullanım imkanı
Kolay taşınabilir özelliği ile farklı yerlerde çalışma
Düzen ve çöpe giden vidalarınızı önler

> FEATURES

Used in windows and doors manufacturing for reinforced steel, espagnolette and hinge screwing
Pneumatic unit of automatic screw feeding
Speedy and fast usage
With easy movable feature work in different places
Prevents the waste of fallen screws

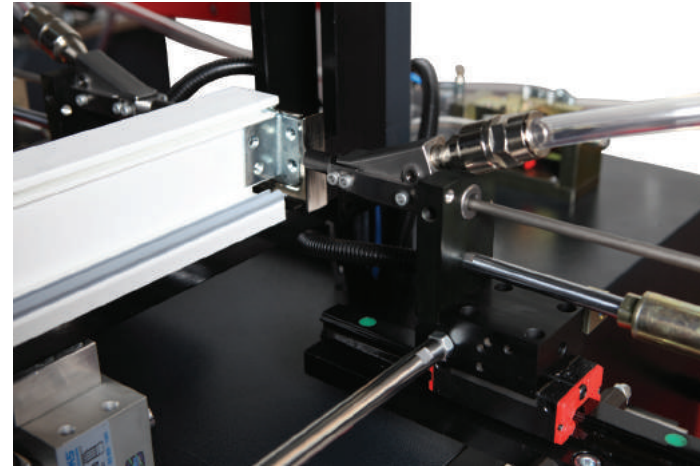
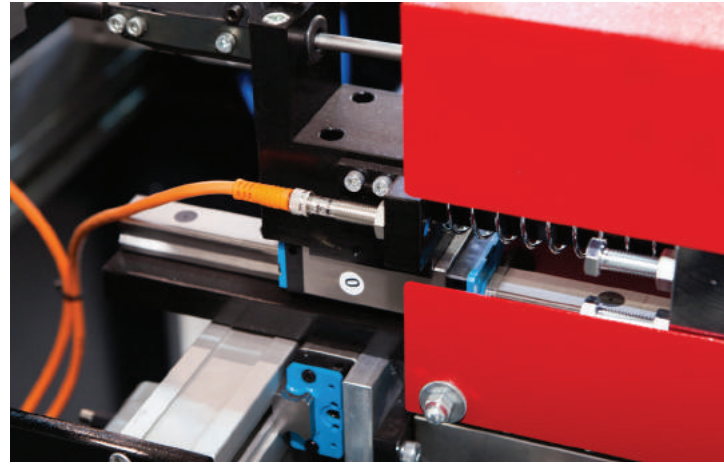
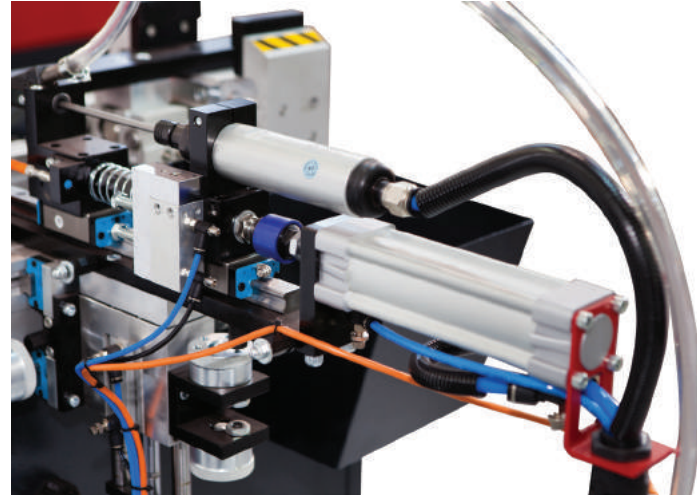

> ÖZELLİKLER

Farklı seri değişik ebatlardaki PVC orta kayıt profillerinde kullanılan orta kayıt bağlantı takozlarını konumlayarak ayar gerektirmeden tek seferde her iki taraftan otomatik vidalama işlemi yapar.
Aynı anda ayar gerektirmeden 6 farklı seri orta kayıt kullanma imkanı
Çift taraflı otomatik vida besleme ünitesi ile otomatik vidalama
Otomatik baskı ve profil merkezleme sistemi
Kolay ayar imkanı ve pozisyon değiştirme
Bir adet takoz bağlama süresi 6 sn.

> FEATURES

Automatic screwing of mullion connectors used on different series and sizes of PVC mullion profiles, in one time from both sides, positioning without settings.
Possibility to use 6 types of mullion connector in the same time without change settings
Automatic screwing with double side automatic screw feeding unit
Automatic clamp and profile centering system
Possibility for easy setting and position change
Connector joining speed 6 sec/pcs

CS/801 AUTOMATIC MULLION CONNECTOR JOINING

OTOMATİK ORTA KAYIT TAKOZ
BAĞLAMA SİSTEMİ

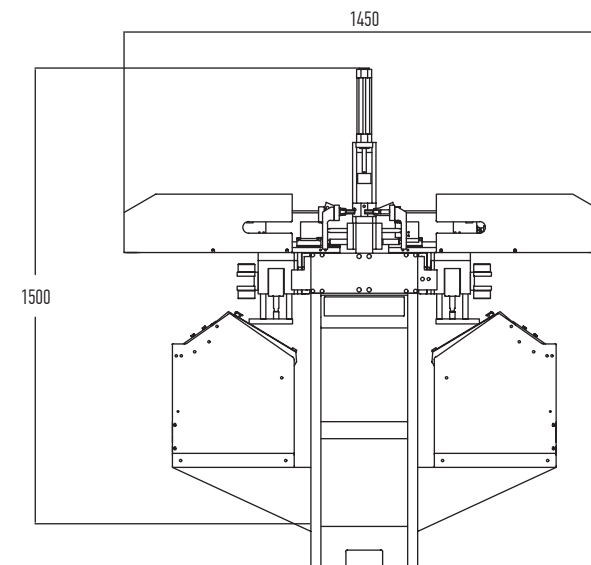
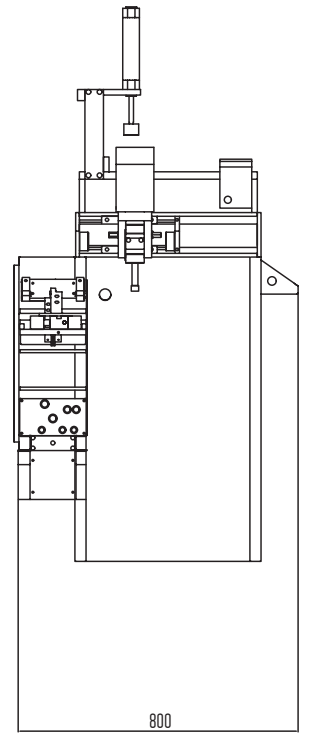

A min : 40 mm A max : 165 mm B min : 40 mm B max : 100 mm	Min : 3,9 x 16 Max : 4,2 x 38	6-8 bar 60/t/syc	180 kg	1500 x 900 x 1750	V : 220 A : 2 Hz : 50

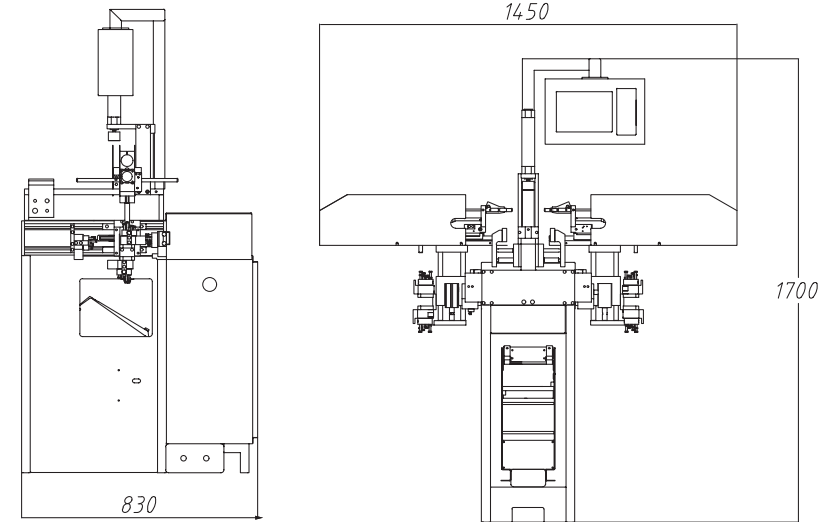
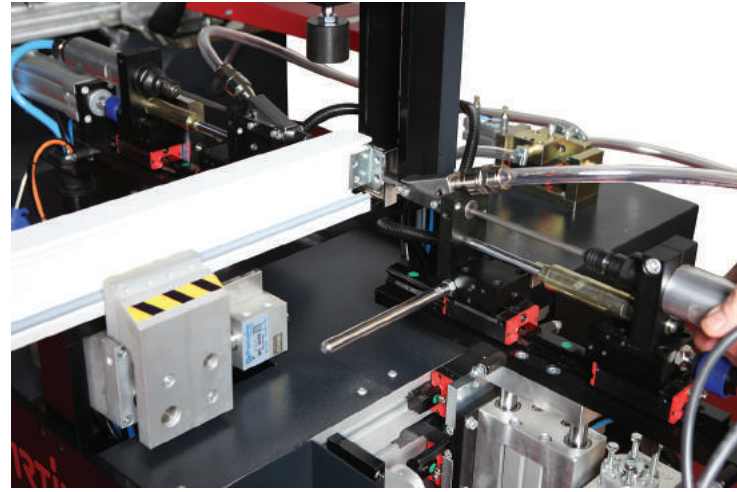
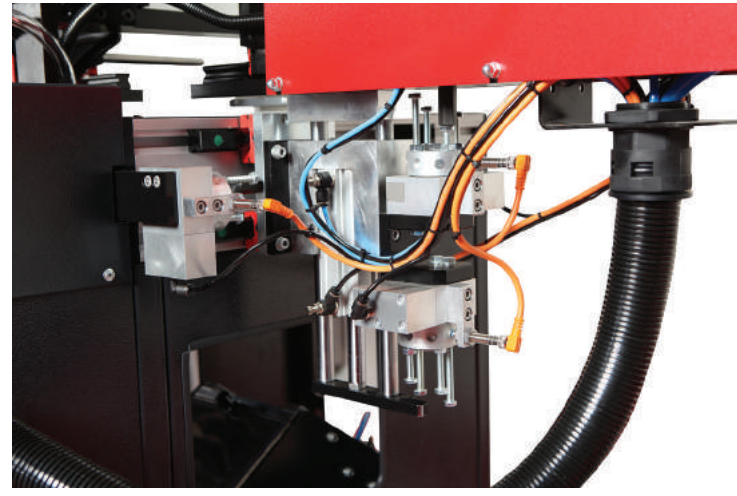
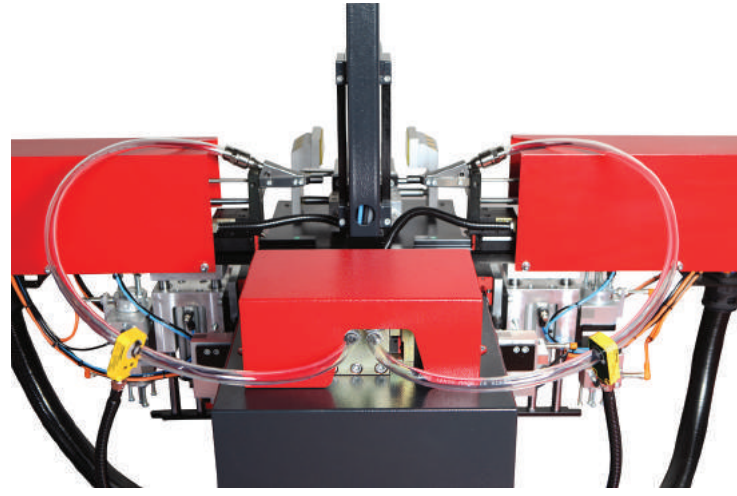

> ÖZELLİKLER

Farklı seri değişik ebatlardaki PVC orta kayıt profillerinde kullanılan orta kayıt bağlantı takozlarını konumlayarak ayar gerektirmeden tek seferde her iki taraftan otomatik vidalama işlemi yapar. Ekrandan seçerek otomatik revolver sistemi ile 8 farklı profil ölçülerine göre vida atabilme özelliği. Program değişikliği ekrandan özel revolver sistemi ile yapabile imkanı. Çift taraflı otomatik vida besleme ünitesi ile otomatik vidalama. Otomatik revolver sistemi ile konumlayarak farklı orta kayıt takozu programlama. Otomatik baskı ve profil merkezleme sistemi. Bir adet takoz bağlama süresi 6 sn.

> FEATURES

Automatic screwing of mullion connectors used on different series and sizes of PVC mullion profiles, in one time from both sides, positioning without settings. Easy adjustment possibility for 8 different sizes of profiles by revolver system after selected on touch screen for screwing. Automatic screwing with double side automatic screw feeding unit. Automatic positioning for different mullion connectors by revolver system. Automatic clamp and profile centering system. Connector joining speed 6 sec./pcs

CS/803 FULL AUTOMATIC MULLION CONNECTOR JOINING DIGITAL CONTROL

TAM OTOMATİK ORTA KAYIT TAKOZ
BAĞLAMA MAKİNASI DİJİTAL KONTROL



A min : 40 mm A max : 165 mm B min : 40 mm B max : 100 mm	Min : 3,9 x 16 Max : 4,2 x 38	6-8 bar 60/lt/syc	165 kg	1500 x 950 x 1750	V : 220 A : 2 Hz : 50

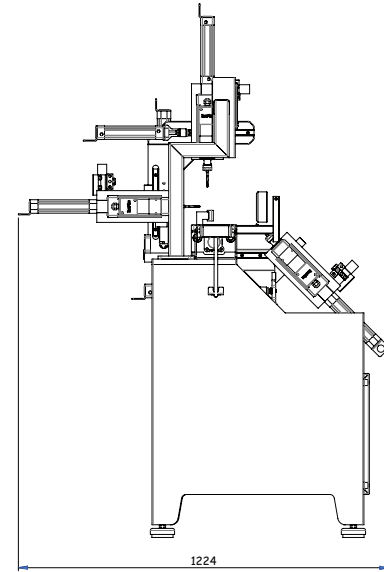
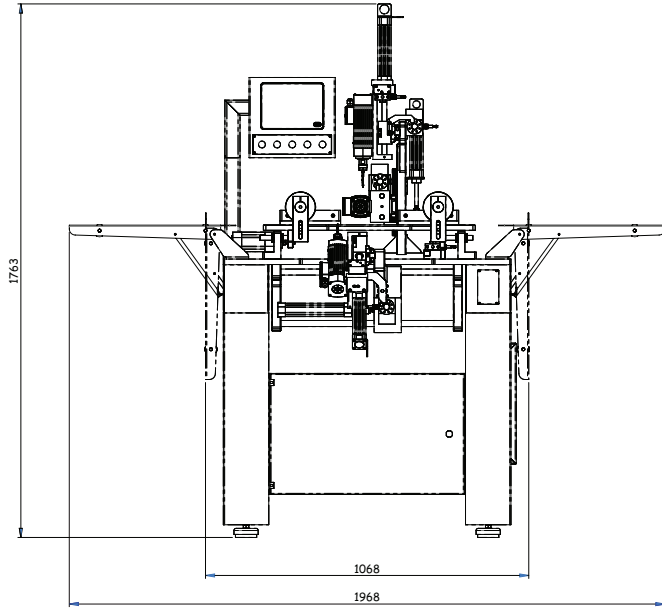
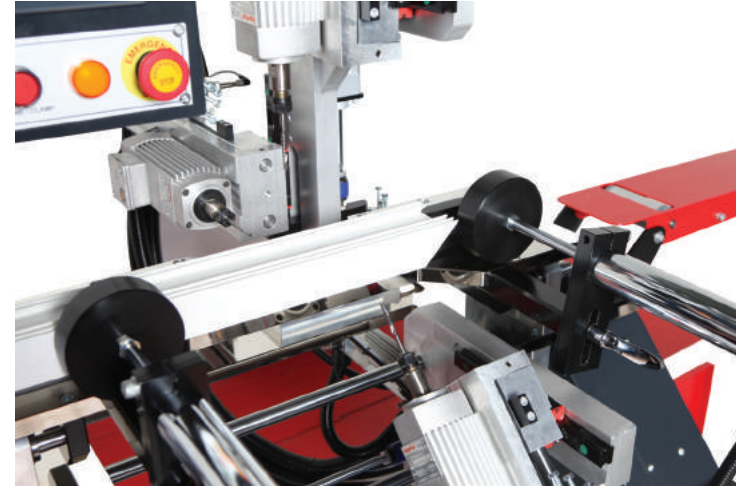
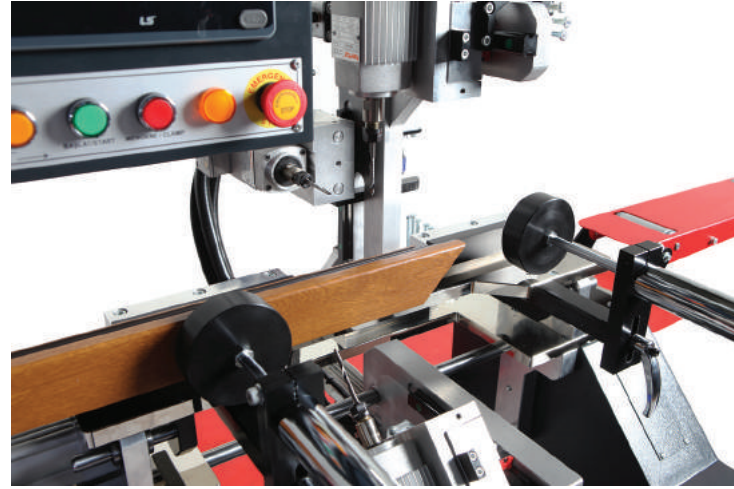
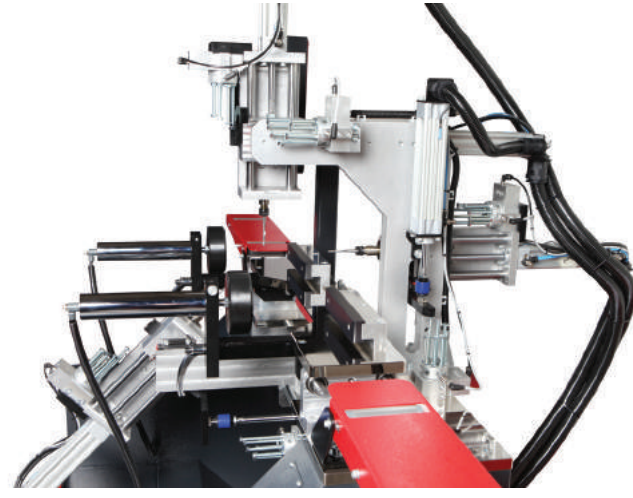

> ÖZELLİKLER

Farklı seri değişik ebatlardaki kapı pencere profilleri üzerindeki su tahliye kanal açma işlemini yapar.

Tek butona basarak delme işlemi otomatik olarak başlatılır

Butonlar ile motor seçimi

Üç motor beraber veya ayrı kullanılabilme özelliği vardır

Yüksek devirli motor kullanılmaktadır

PLC kontrol sistemi

Ekrandan seçerek otomatik revolver sistemi ile 8 farklı profil ölçülerine göre kanal açma ayar geçişi.

> FEATURES

Water slot drilling on PVC window and door profiles with different type and sizes

Automatic starting the process by pushing the single button

Selection the motor by switch button

The routing units can be used together or separately from each other

Used high frequency motors

PLC control system



The special revolver change system for fast adjustable operation between different profiles

Easy adjustment possibility for 8 different sizes of profiles by revolver system after selected on touch screen for water slot drilling.

WS/303 FULL AUTOMATIC WATER SLOT DRILLING MACHINE DIGITAL CONTROL

TAM OTOMATİK SU TAHLİYE FREZE MAKİNASI
DİJİTAL KONTROL

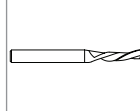
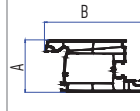
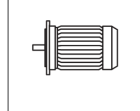

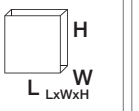
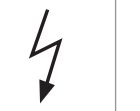
						
40 x 90 x 5 mm L55	A min : 40 mm A max : 160 mm B min : 40 mm B max : 110 mm	3 x 0,75 kW 18000 rpm	6-8 bar 25/t/syc	215 kg	1150 x 1300 x 1850 LxWxH	V : 380 Hz : 50

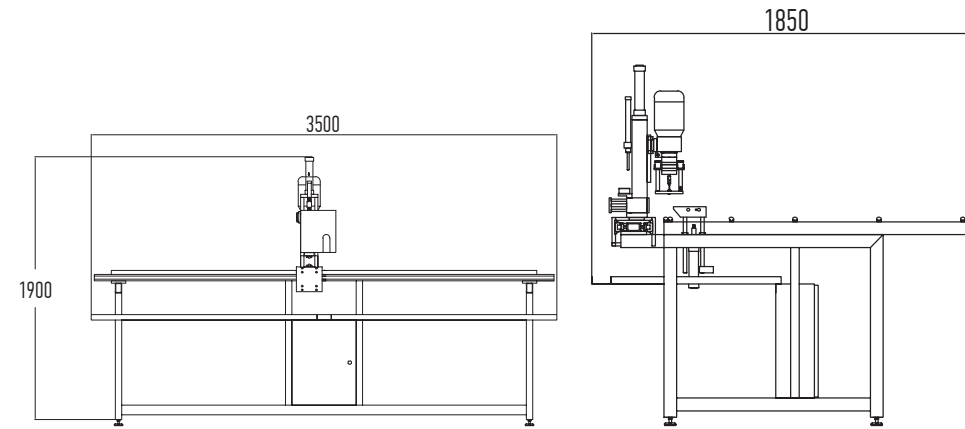
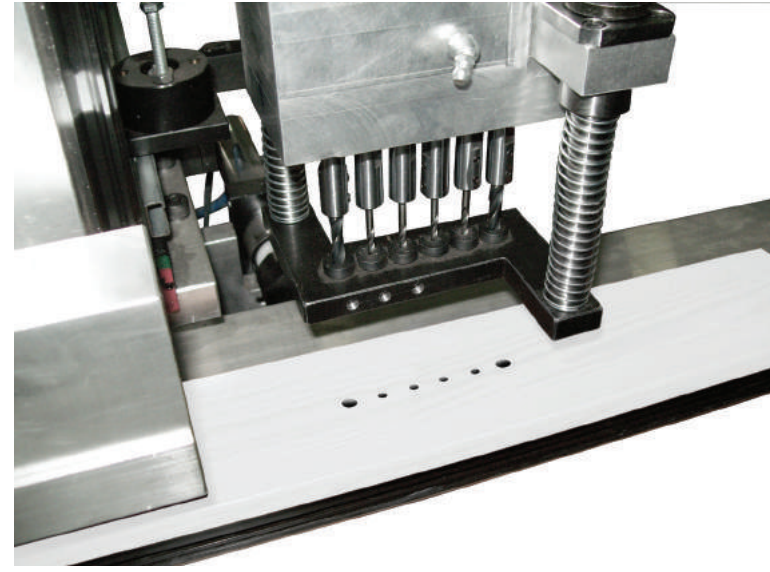
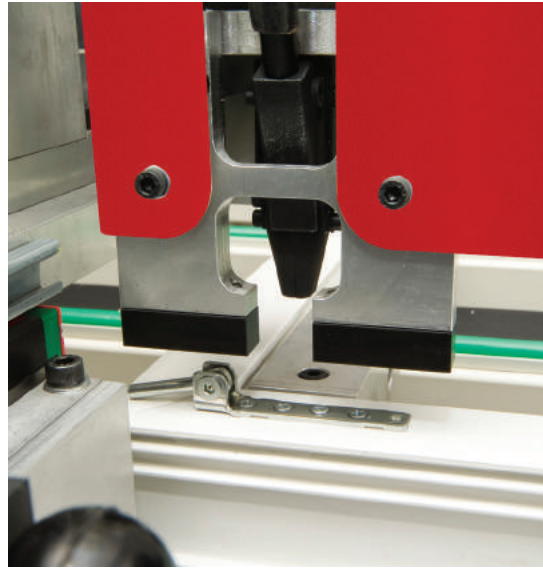

> ÖZELLİKLER

Farklı seri değişik ebatlardaki kapı & pencere kasa profilinde kullanılan çift açılım aksesuar menteşelerini metre, kalemli şablon kullanmadan çoklu delme sistemi ile tek seferde delme işlemi ve otomatik vidalama yapar.

Otomatik merkezleme ile kasa sabitleme

Kullanılan aksesuara göre yatay ve dikey hareketli çoklu delme ünitesi

Tek hareket ve buton ile tüm menteşe pimleri ve vida yerlerini delme imkanı

> OPSİYONLAR

ASD- Tam Otomatik Vidalama. Otomatik Vida Besleme ünitesi ve Lazer Vida Hizalama Sistemi

> FEATURES

Allows to drill holes in one time by multi drilling system and automatic screwing of tilt&turn hardware hinges used on different series and sizes of window & door frame profiles, without tape measure, pencil and template using.

Frame fixing with automatic centering

According the furniture type horizontal and vertical action usable multi drilling unit

Possibility to drill all hinge holes and screw places with single move by one button

OPTIONS

> ASD- Full automatic vertical screwdriverAutomatic screw feeding unit. Laser pointer.

FS/701

FRAME ASSEMBLY TABLE

KASA TOPLAMA MASASI

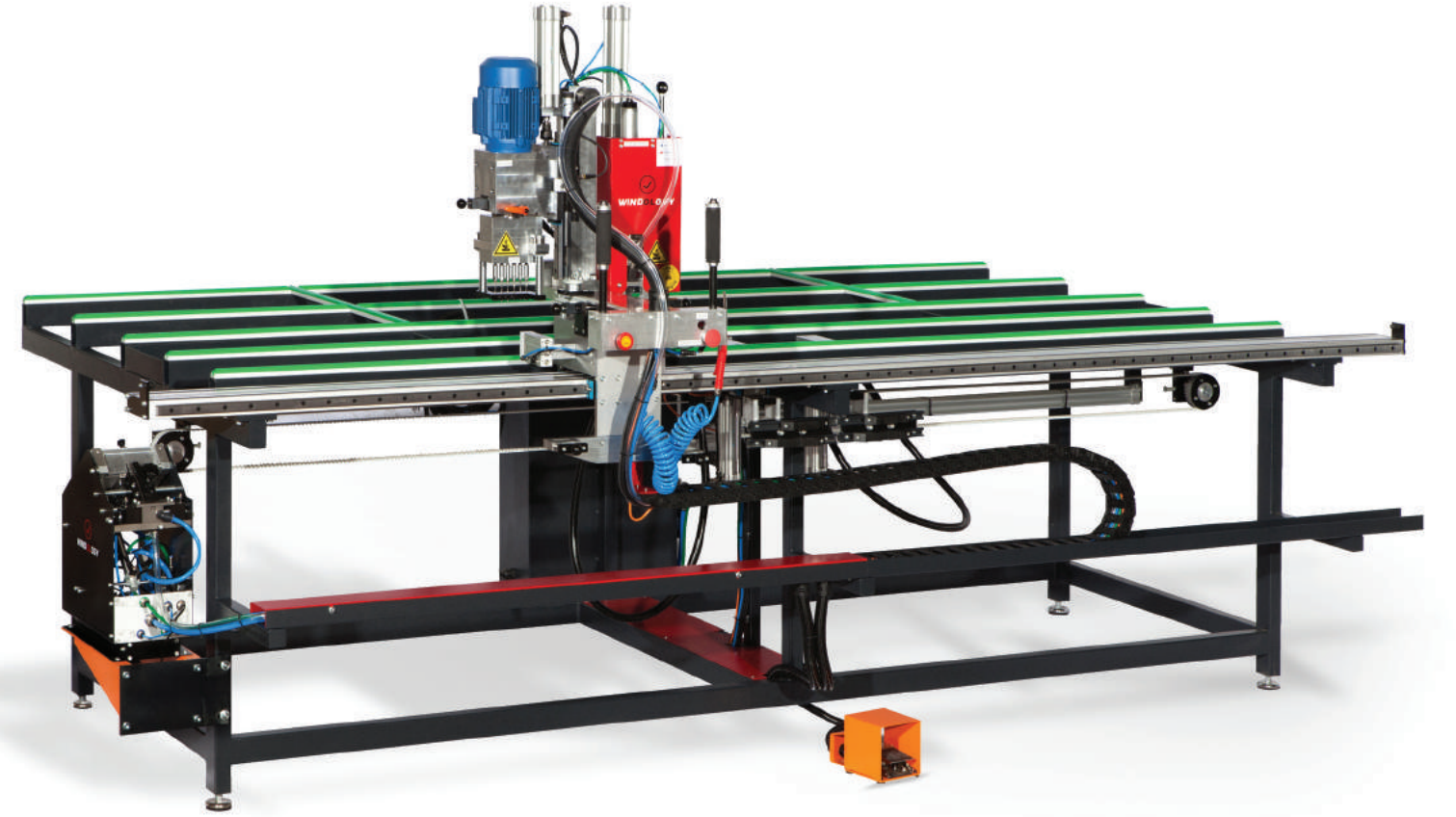

A Min : 450 A Max : 2300	A min : 40 mm A max : 210 mm	Min : 3,9 x 16 Max : 4,2 x 38	6-8 bar 30/t/syc	580 kg	3500 x 1850 x 1900	V : 380 A : 2 kW : 0,75 Hz : 50

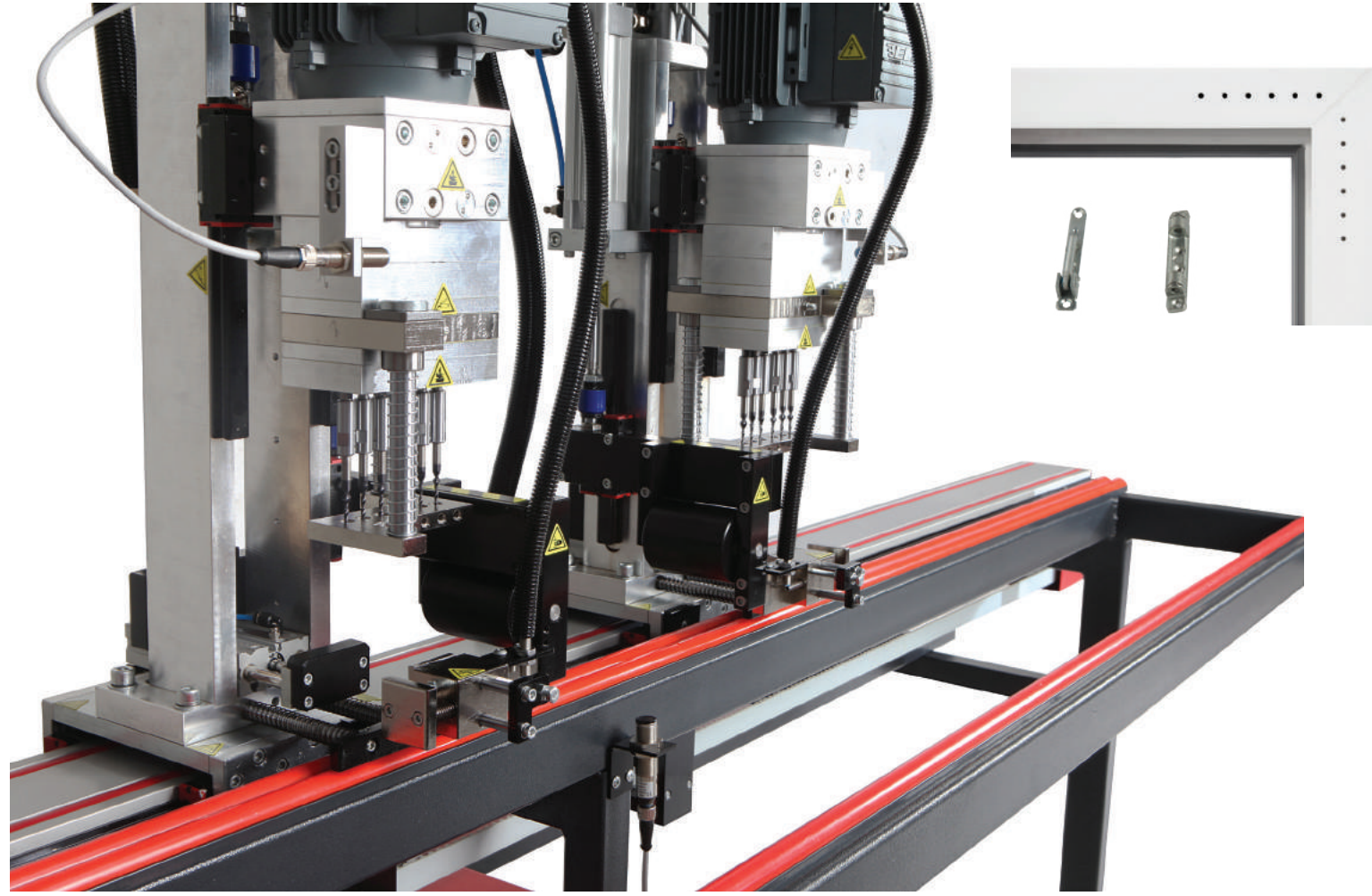

FS/751

DOUBLE HEAD FRAME HINGE DRILLING MACHINE

ÇİFTLİ KASA MENTEŞE YERİ DELME MAKİNASI

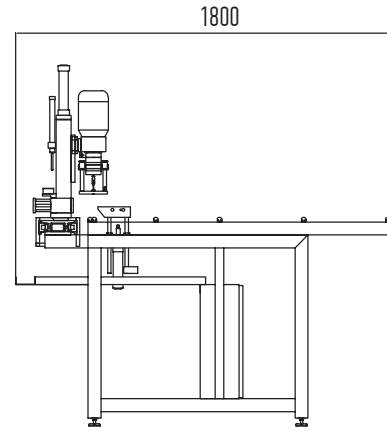
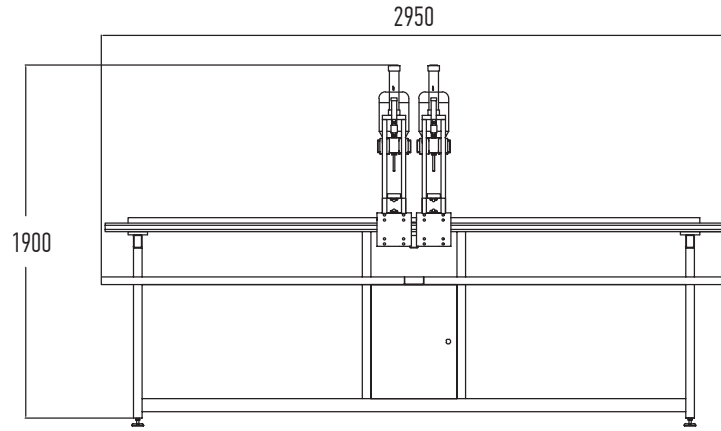

ÖZELLİKLER

Farklı seri değişik ebatlardaki kapı & pencere kasa profilinde kullanılan çift açılım aksesuar menteşelerini metre, kalemi, şablon kullanmadan çoklu delme sistemi ile tek seferde delme işlemi yapar.
Otomatik merkezleme ile kasa sabitleme
Kullanılan aksesuara göre dikey hareketli çift kafalı çoklu delme ünitesi
Tek hareket ve buton ile tüm menteşe pimleri ve vida yerlerini destek sacı ile birlikte delme imkanı
Her türlü kasa profili için uyumludur

FEATURES

Allows to drill holes in one time by multi drilling system of tilt&turn hardware hinges used on different series and sizes of window & door frame profiles, without tape measure, pencil and template using.
Frame fixing with automatic centering
According the furniture type vertical action usable double head multi drilling unit
Possibility to drill all hinge holes in profile with reinforcement steel and screw places with single move by one button
Suitable for all types of frame profiles.

A Min : 450 A Max : 2200	A min : 40 mm A max : 210 mm	V : 380 kW : 1	6-8 bar 30/t/syc	280 kg	2950 x 1800 x 1900

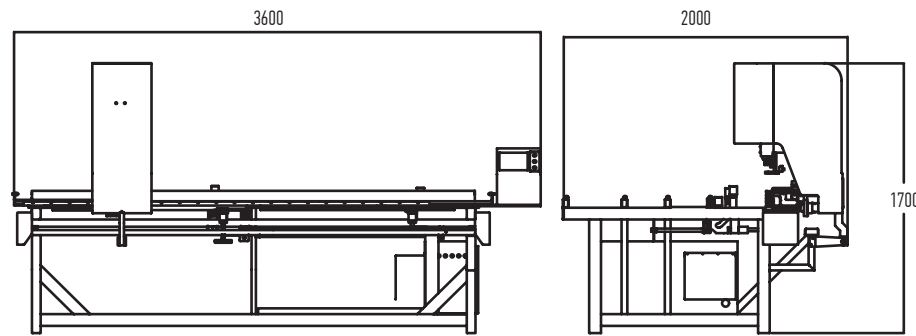

> ÖZELLİKLER

- Çift Kafa Kasa Toplama Masası (Servo Kontrollü)
- Pencere Kasası Otomatik Merkezleme (Otomatik Pozisyonlama)
- Otomatik Ölçü Alma (Servo Kontrollü)
- Her çeşit ve adet menteşe için uyumlu
- Servo kontrollü 3D menteşe delme ünitesi

> FEATURES

- Double head frame assembly table. (Servo controlled)
- Automatic centering of window's frame (Automatic positioning)
- Automatic measurement system (Servo controlled)
- Compatible with all amount & kind of hinges
- 3D hinges servo controlled drilling unit

FS/771

DOUBLE HEAD FRAME ASSEMBLY TABLE

SERVO CONTROL

ÇİFT KAFA KASA TOPLAMA MASASI
SERVO KONTROLLÜ



A Min : 450 A Max : 2720	A min : 40 mm A max : 210 mm	V : 380 kW : 1	6-8 bar 30/t/syc	580 kg	3600 x 2000 x 1700

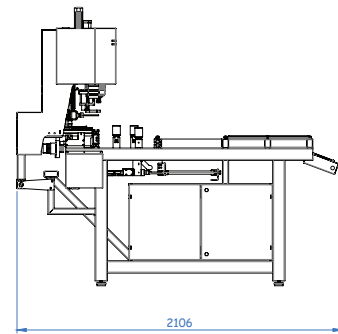
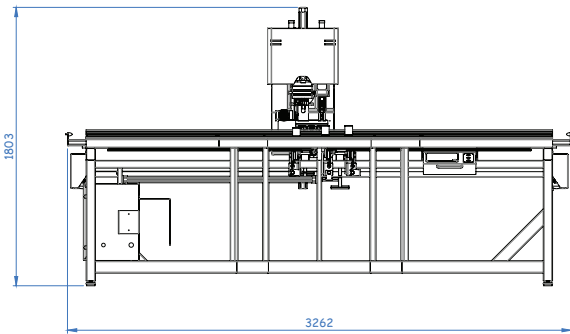

> ÖZELLİKLER

- Üç Kafa Kasa Toplama Masası (Servo Kontrollü)
- Pencere Kasası Otomatik Merkezleme (Otomatik Pozisyonlama)
- Otomatik Ölçü Alma (Servo Kontrollü)
- Her çeşit ve adet menteşe için uyumlu
- Servo kontrollü 3D menteşe delme ünitesi
- Yatay kanat kapı menteşe delme ünitesi

> FEATURES

- Triple head frame assembly table. (Servo controlled)
- Automatic centering of window's frame (Automatic positioning)
- Automatic measurement system (Servo controlled)
- Compatible with all amount & kind of hinges
- 3D hinges servo controlled drilling unit
- Horizontal drilling for hinge of door sash profile

FS/775

TRIPLE HEAD FRAME ASSEMBLY TABLE

SERVO CONTROL

ÜÇ KAFA KASA TOPLAMA MASASI
SERVO KONTROLLÜ



A Min : 450 A Max : 2720	A min : 40 mm A max : 210 mm	Min : 380 kW : 1	6-8 bar 30 lt/syc	560 kg	3590 x 1940 x 1775

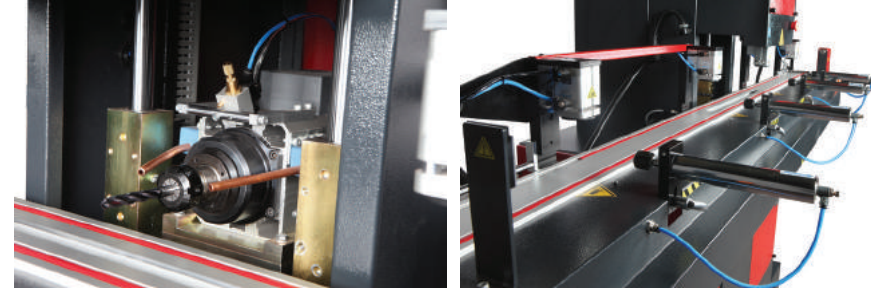
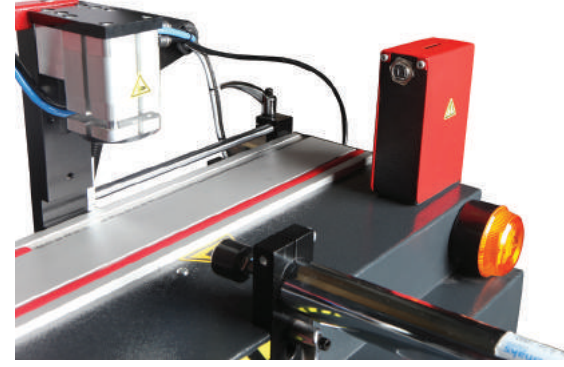
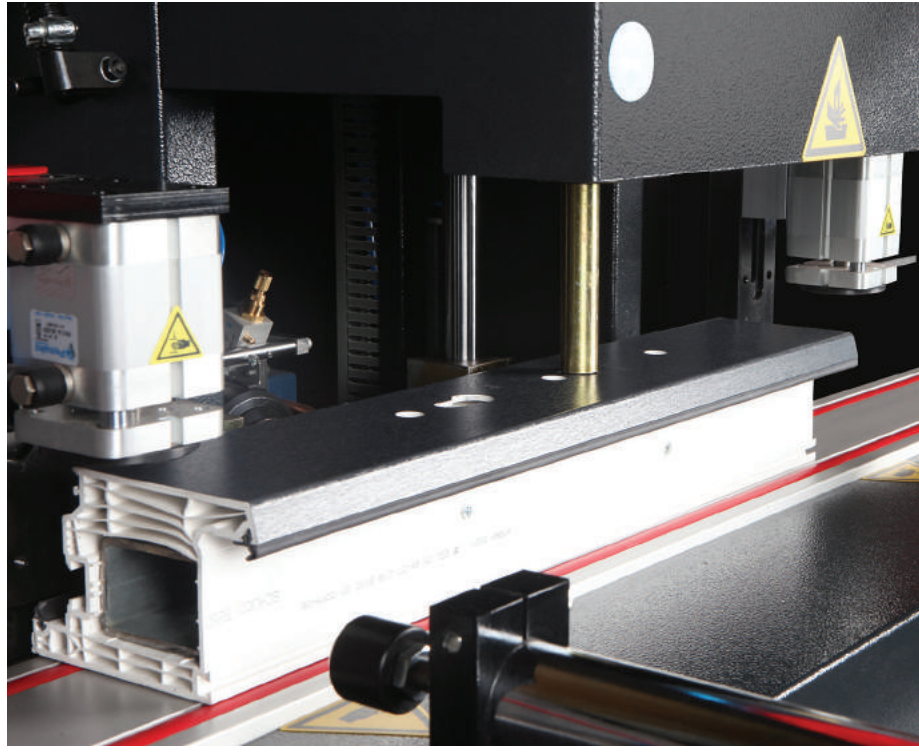

DG/604 CNC DOOR PROCESSING CENTER

CNC KAPI İŞLEME MERKEZİ



ÖZELLİKLER

Farklı seri değişik ebattardaki pvc kapı kanat profillerinde kullanılan: tüm kilitli kapı ispanyoleti, wc kilit, oda kapı kilidi kol montajı deliklerini kol demiri deliğini ve kilit kanal yuvasını metre kalem kullanmadan, profilü çevirmeden makina başında beklemeden destek sacı ile birlikte sorunsuz ve sıfır hata ile açma işlemi yapar
Çoklu kilitli kol ve sistemi programlama
Kancalı kilitli kapı ispanyoletlerini tek seferde açma işlemi
Kutu destek sacı kanal açma sistemi
Sensörlü güvenlik bariyer
Hareketli konveyör ikaz ışığı

FEATURES

Used for drilling operations in a door sash of different types and series of PVC profiles with reinforcement steel inside. Used for: all types of mechanisms of vertical locks; locks for the toilet/bath (WC); locks with cylinder mechanism; locks for room doors; handle assembling holes; cylinder mechanism and channel lock slot
Multilock handle and sistematic programming
Special door lock espagnolette holes finish in one operation
Channel grooving for profile with square reinforced steel
Sefaty guard sensor
Movable conveyor warning lights

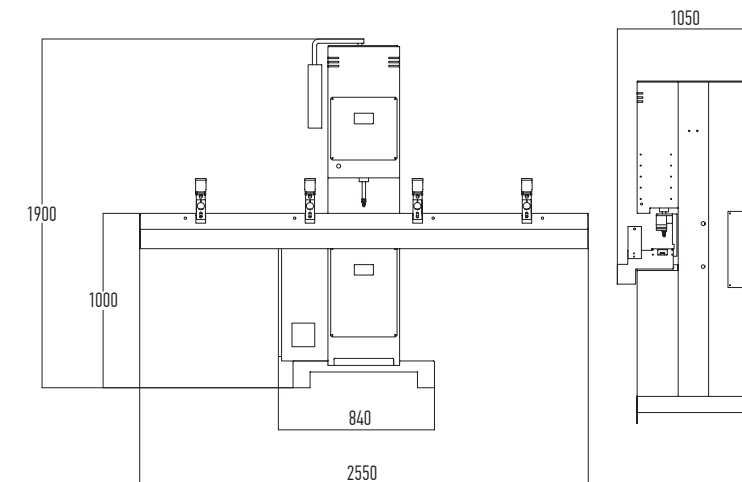

A min : 45 mm A max : 100 mm B min : 40 mm B max : 120 mm	V : 380 kW : 3 A : 8	6-8 bar 60/l/syc	400 kg	2600 x 1000 x 2150

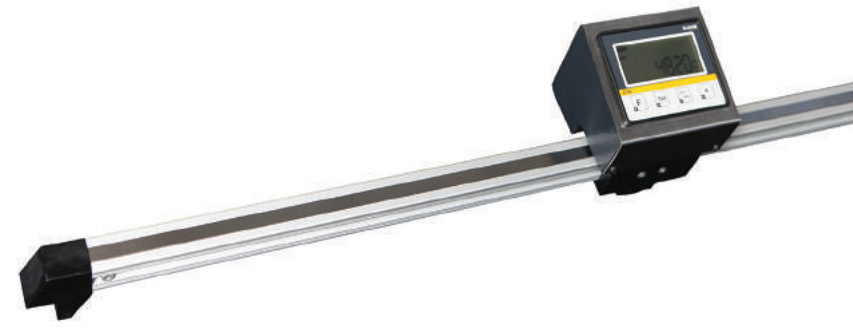
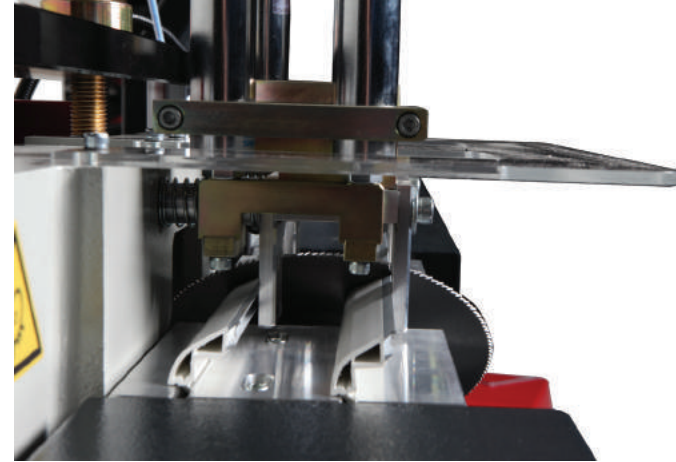
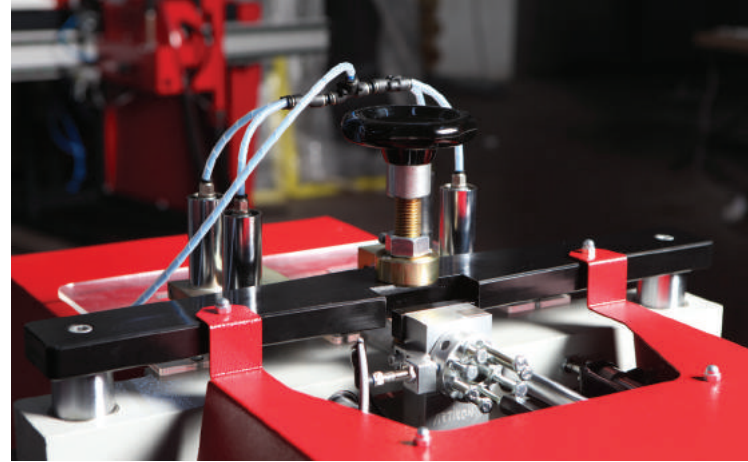
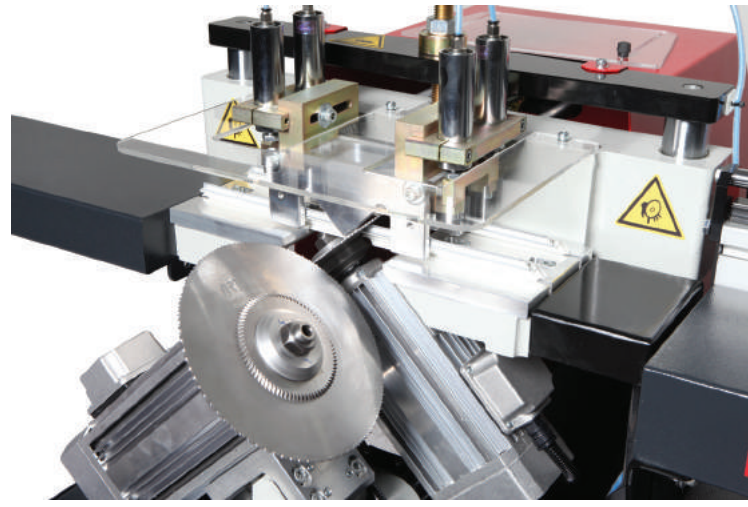

> ÖZELLİKLER

- PVC çita profillerinin servolu konveyör ile otomatik kesimi
- Kesme hız ayar sistemi
- Kalipsiz sistemi yardımı ile her çeşit çita kesme imkanı.
- Kaynatılmış çerçeveden dijital ölçüm aparatı ile hassasiyetle ölçü alabilme
- Aktarılan ölçülere veya ekrandan girilen ölçüler ile konveyörün kendini servomotor ile pozisyonlaması
- Aynı anda çift çita kesme imkanı.
- Ekrandan seçerek otomatik revolver sistemi ile 8 farklı profil ölçülerine göre ayar imkanı
- USB ile CSV formatında ölçü aktarma

> OPSİYONLAR

- Dijital kumpas ölçme sistemi.
- Kanat toplama makinasından ölçü alabilme

> FEATURES

- Automatic cutting of glazing bead PVC profiles with servo conveyor
- Cutting speed arrangement system
- Moldless cutting possibility for every type of glaz bead
- Exact measurement of welded construction with a digital measuring system
- Easy data transfer from the measuring device to the machine via Bluetooth
- Positioning of conveyor by servomotor on transferred sizes or inputted sizes from screen
- Ability to cut two glazing beads at same time.
- Easy adjustment possibility for 8 different sizes of profiles by revolver system after selected on touch screen
- Loadind the CSV data file with cutting sizes by USB

> OPTIONS

- Digital ruler measuring system.
- Take a measurre from Sash Assembly Unit

BS/401



DIGITAL GLAZING BEAD SAW

MOULDLESS SYSTEM

DIJİTAL ÇİTA KESME MAKİNASI

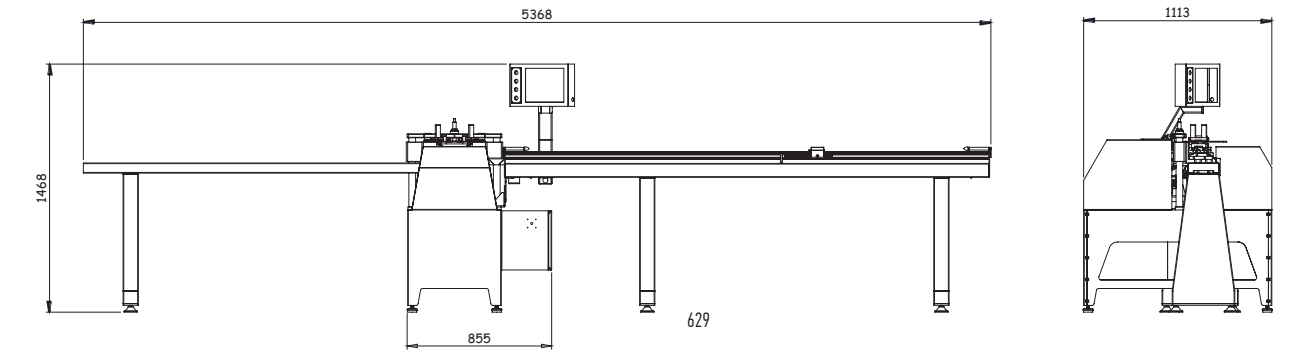
KALIPSIZ SİSTEM

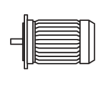

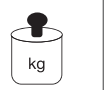
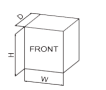
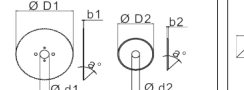
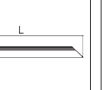
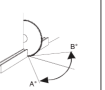
							
Hz 50 2800 rpm 230/400 V	V 380 kW 2,5	Air 6-8 bar 25 lt/min	275 kg	H = 1450mm W = 1200mm D = 1350mm	ØD1 = 200mm Ød1 = 32mm b1 = 1,8mm z1 = 160	ØD2 = 100mm Ød2 = 25mm Øb2 = 3mm Z = 80 a° = 45°	L min 240 L max 2450 H max 27mm

DC/401

DIGITAL CONVEYOR

DIJİTAL KONVEYÖR

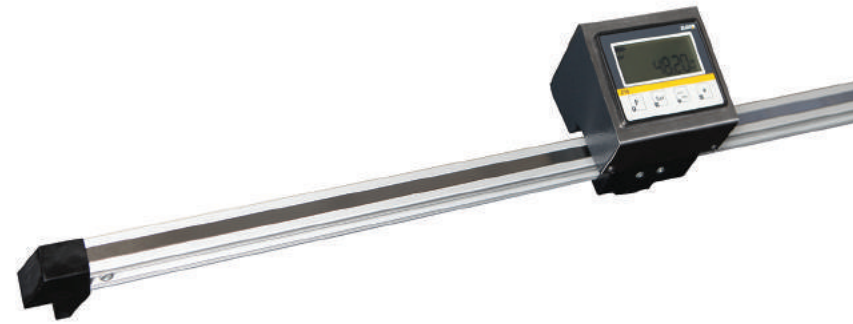

> ÖZELLİKLER

Aktarılan ölçülere veya ekrandan girilen ölçüler ile konveyörün kendini servomotor ile pozisyonlaması
Kaynatılmış çerçeveden dijital ölçüm aparatı ile hassasiyetle ölçü alabilme
USB ile CSV formatında ölçü aktarma

> OPSİYONLAR

Dijital kumpas ölçme sistemi.
Kanat toplama makinasından ölçü alabilme

> FEATURES

Positioning of conveyor by servomotor on transferred sizes or inputted sizes from screen
Exact measurement of welded construction with a digital measuring system
Loadind the CSV data file with cutting sizes by USB

OPTIONS

> Digital ruler measuring system.
Take a measure from Sash Assembly Unit

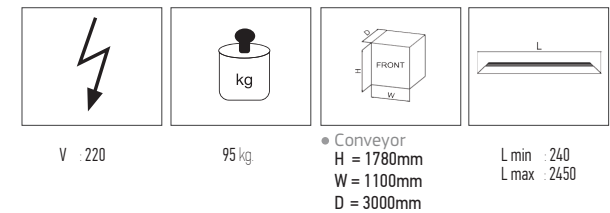
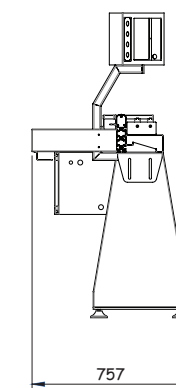
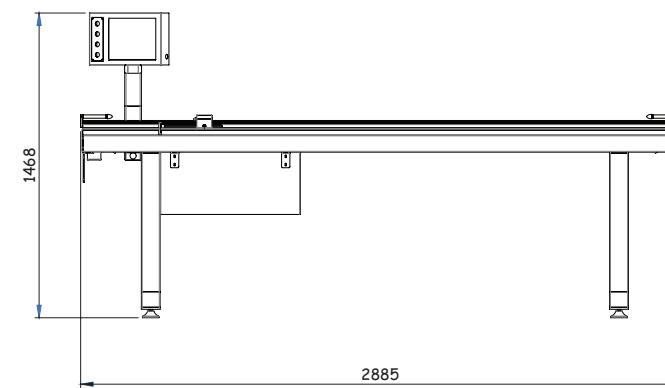

BS/400

MANUAL GLAZING BEAD SAW

MOULDLESS SYSTEM

MANUEL ÇITA KESME MAKİNASI
KALIPSIZ SİSTEM

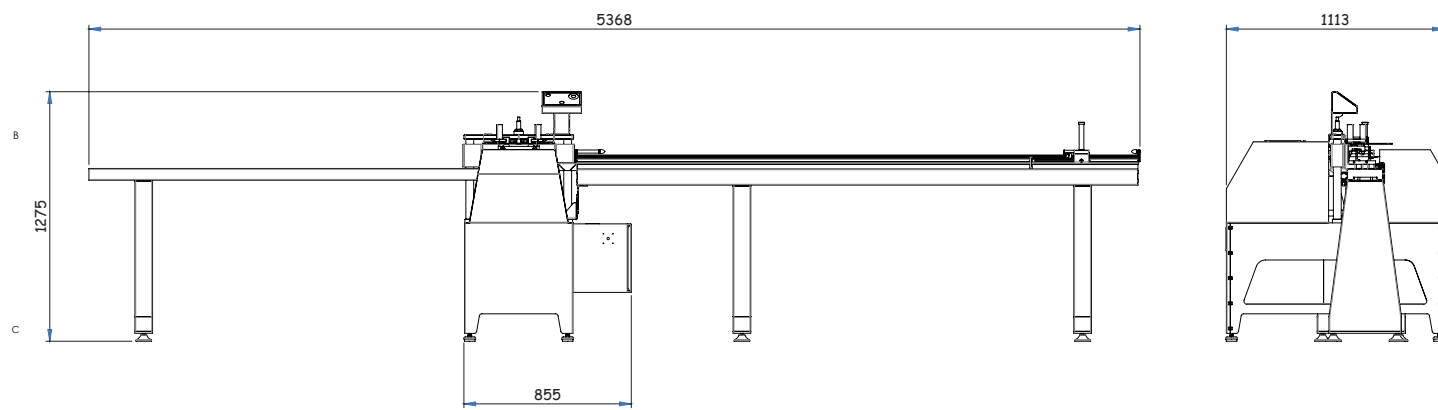
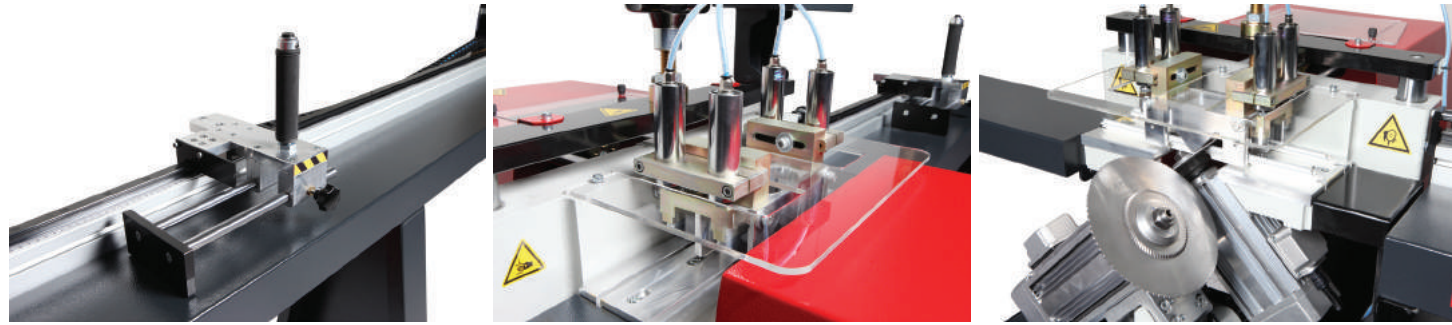





> ÖZELLİKLER

PVC çita profillerinin otomatik kesimi
8 farklı çita profiline göre manuel revolver sistemi.
Kesme hız ayar sistemi
Kalıpsız sistemi yardımı ile her çeşit çita kesme imkanı.
Aynı anda çift çita kesme imkanı.

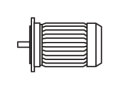
> FEATURES

Automatic cutting of glazing bead PVC profiles
Manual revolver system for 8 different types of glaz bead profiles
Cutting speed arrangement system
Moldless cutting possibility for every type of glaz bead
Ability to cut two glazing beads at same time.

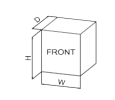
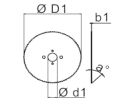
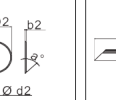
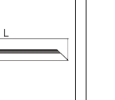
							
Hz 50 2800 rpm 230/400 V	V 380 kW 2,5	Air 6-8 bar 25 lt/min	260 kg	H = 1450mm W = 1200mm D = 1350mm	ØD1 = 200mm Ød1 = 32mm b1 = 1,8mm z1 = 160	ØD2 = 100mm Ød2 = 25mm Øb2 = 3mm Z = 80 a' = 45°	L min 240 L max 2450 H max 27mm

CG/301 CHECKING AND GLAZING UNIT

CAM MONTAJ
ÜNİTESİ

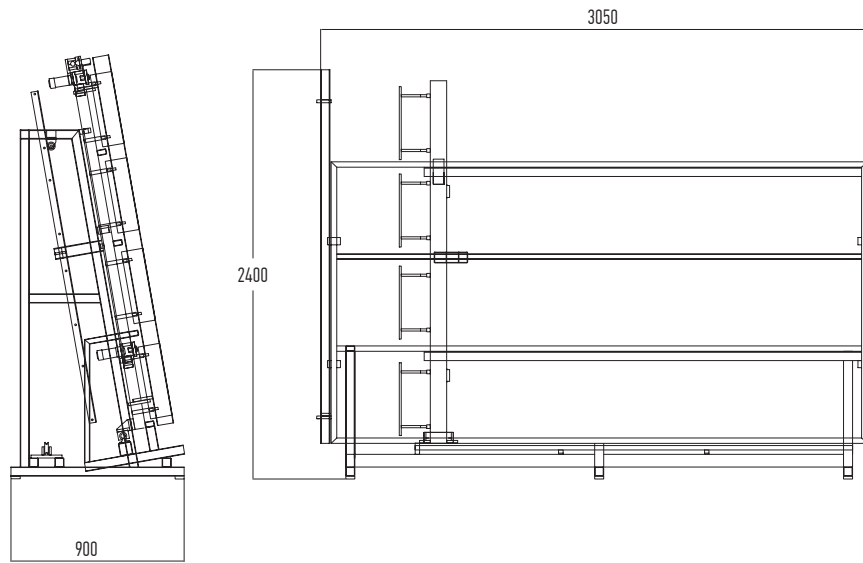

> ÖZELLİKLER

Kapı ve pencerelere seri şekilde cam takma
Camı takılmış doğramayı ambalajlamaya makaralar üzerinde aktarma
Paralel baskı ünitesi ile uygun değerde denge sağlama
Doğramanın yukarı kaldırılması ile montaj kolaylığı

> FEATURES

Fast installation of glass on the windows and doors
Glazed joinery transferring to package on rollers
Parallel block clamps allow you to set an appropriate balance
Raising the workspace up for easier installation.

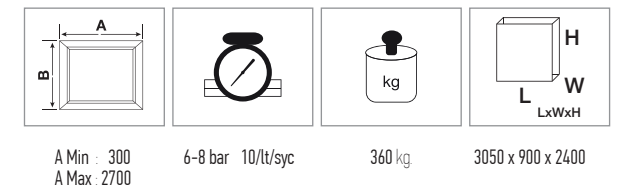

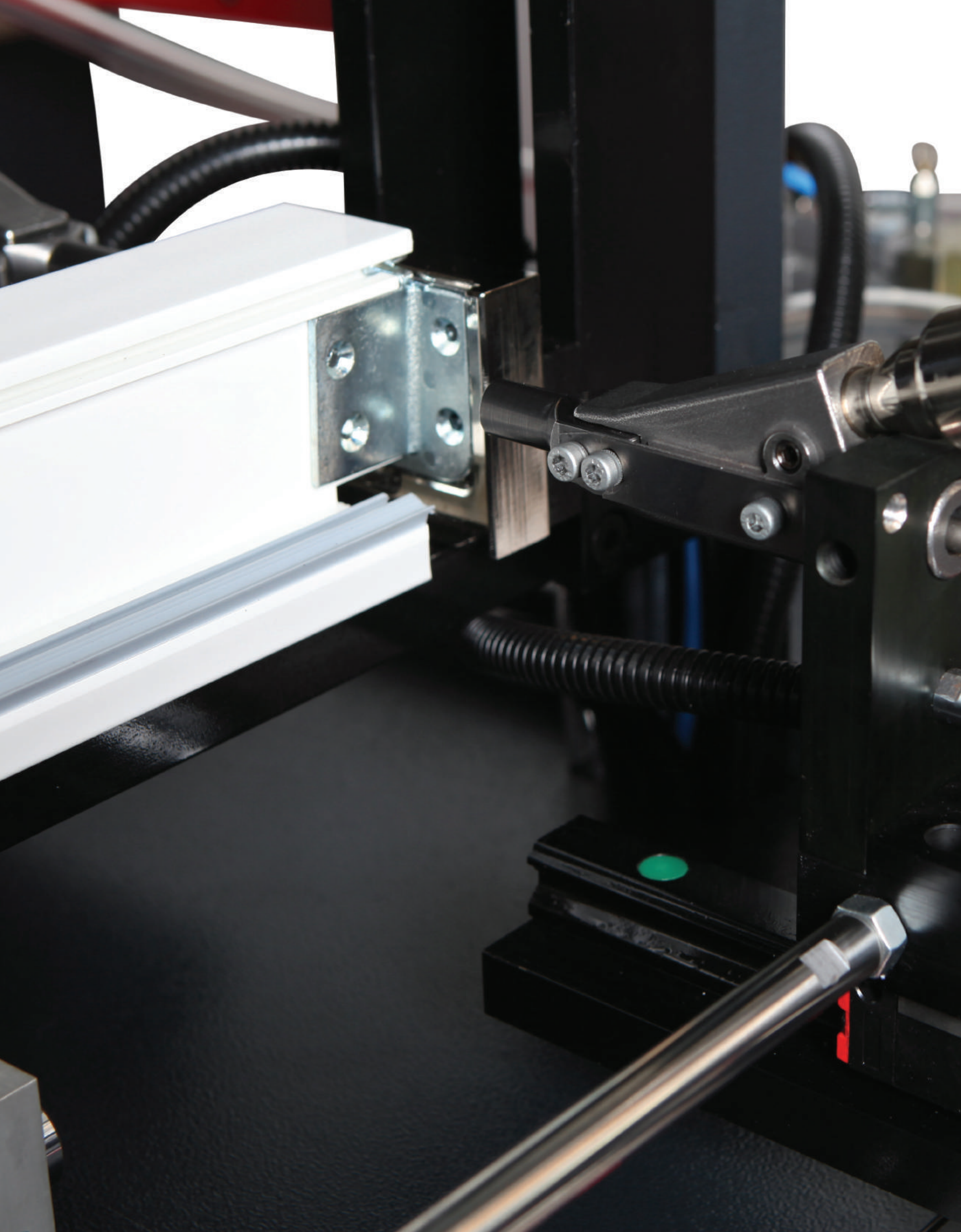

www.osmanliman.com

osmanliman®
WINDOLOGY

ARTIKON®



FABRİKA / FACTORY

OSMANLİMAN MAKİNA SAN. ve TİC. A.Ş.

İkitelli OSB Mah. Atatürk Bulvarı Haseyad 1. Kısım
60/1 2D PK 34490 Başakşehir İSTANBUL / TURKEY

T. +90 212 671 7178

F. +90 212 671 7162

W. +90 532 370 9771

E.

info@osmanliman.com
osman@osmanliman.com
www.osmanliman.com

ARTIKON MAKİNA SRL.

Str.Padurii Nr.49 Arad/ROMANYA

T. +40 357 805 653

F. +40 357 805 653

W. +40 752 117 275

Support T. +40 722 424 962

E.

mliman@artikonmakina.ro
www.artikonmakina.ro